

MODEL C
ELECTRIC HYDRAULIC PUMP
WITH REMOTE CONTROLLED SOLENOID VALVE

GENERAL ASSEMBLY

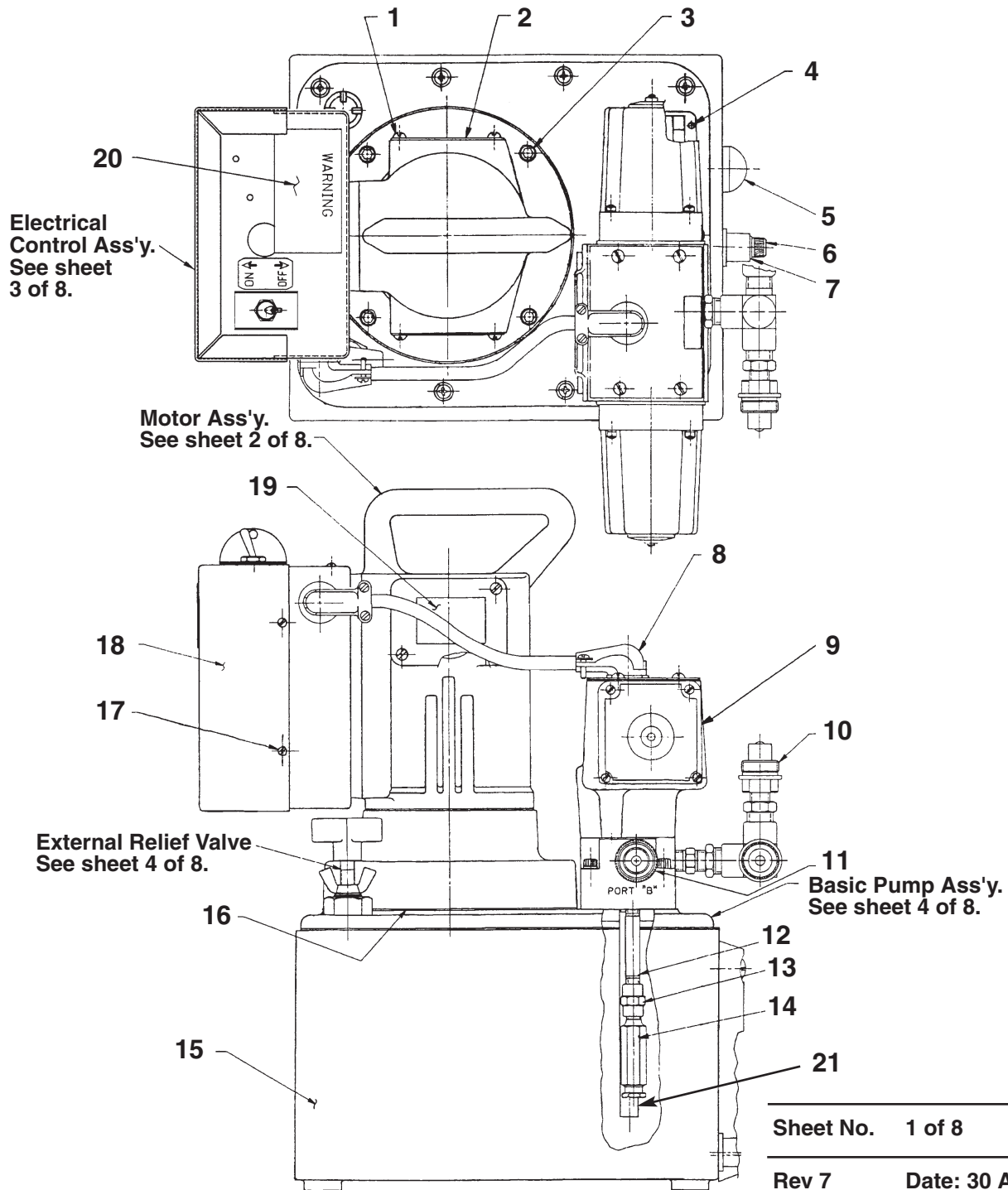

Parts List, Form No. 100581, Back sheet 1 of 8

Item No.	Part No.	No. Req'd	Description
1	10164	4	Machine Screw (10-24 UNC x 3/8 Lg.)
2	21008	2	Cover
3	10022	4	Cap Screw (1/4-20 UNC x 1-1/2 Lg.)
4	10575	4	Drive Screw (#2 X 3/16 Lg.)
5	350431	1	Sight Gauge
6	10412	1	Cap Screw (3/8-16 UNC x 1/2 Lg.)
7	19779	1	Washer
8	11144	1	90° Conduit Connector
9	66205-115	1	Valve (For SST-10; See Form No. 108066)
	61084-100	1	Valve (For SST-100; See sheet 7 of 8)
	66205-230	1	Valve (For SST-20; See Form No. 108066)
	61084-200	1	Valve (For SST-200; See sheet 7 of 8)
10	351076	1	Tee Assembly
11	251410	1	Coupler
12	15456	1	Nipple Fitting
13	18841	1	Straight Fitting
14	21278-15	1	Relief Valve Assembly (Set at 1,500/1,700 PSI)
15	64364BK2	1	Reservoir
16	30650	1	Gasket
17	14812	4	Self-tapping Screw (#8-18 X 3/8 Lg.)
18	43126WH2	1	Cover
19	215164	1	Specifications Decal (For SST-10 & SST-100)
	215163	1	Specifications Decal (For SST-20 & SST-200)
20	250447	1	Warning Decal
21	200609	1	Drain Tube (For SST-10)

Note: Shaded areas reflect last revision(s) made to this form.

Refer to any operating instructions included with this product for detailed information about operation, testing, disassembly, reassembly, and preventive maintenance.

Items found in this parts list have been carefully tested and selected. **Therefore: Use only genuine Power Team replacement parts!**

Additional questions can be directed to our Technical Services Department.

UNIVERSAL MOTOR ASSEMBLY

12,000 RPM -- 115 or 230 Volt, 50/60 Hz.

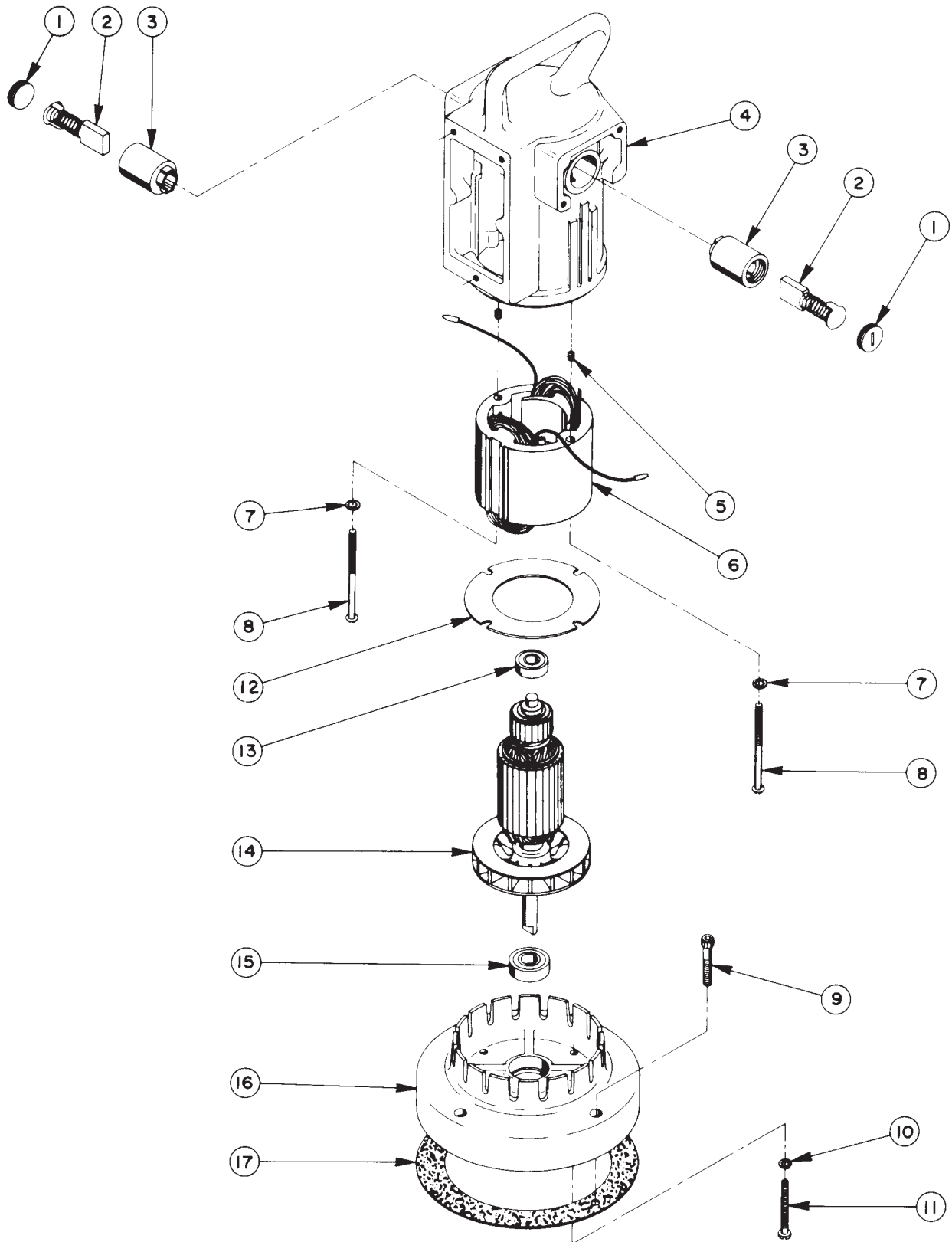

Item No.	Part No.	No. Req'd	Description
1	10806	2	Brush Holder Cap
2	10804	2	Brush Assembly
3	10805	2	Brush Holder
4	50160	1	Motor Shell (For SST-10 & SST-20)
	61901	1	Motor Shell (For SST-100 & SST-200)
5	10133	2	Set Screw
6	10802	1	Field (115 Volt; For SST-10 & SST-100)
	252311	1	Field & Armature (230 Volt; For SST-20 & SST-200; NOTE: Field and armature must be replaced as a set. See Item #14)
7	12356	2	Lockwasher
8	10170	2	Rd. Hd. Machine Screw (10-24 UNC x 3-1/4 Lg.)
9	10022	4	Soc. Hd. Cap Screw (1/4-20 UNC x 1-1/2 Lg.)
10	10241	4	Lockwasher
11	10169	4	Pan Hd. Machine Screw (10-24 UNC x 2" Lg.; Torque to 20/25 in. lbs.)
12	20786	1	Baffle Plate
13	10438	1	Ball Bearing
14	10800	1	Armature (115 Volt; For SST-10 & SST-100)
	252311	1	Field & Armature (230 Volt; For SST-20 & SST-200; NOTE: Field and armature must be replaced as a set. See Item #6)
15	10439	1	Ball Bearing
16	40059	1	Motor Base
17	30650	1	Gasket

BRUSH HOLDER & ARMATURE INSTALLATION SPECIFICATIONS

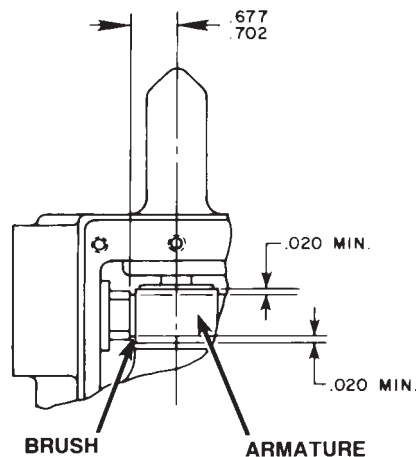

Note: Shaded areas reflect last revision(s) made to this form.

ELECTRICAL CONTROL ASSEMBLY (115 Volt Unit Shown)

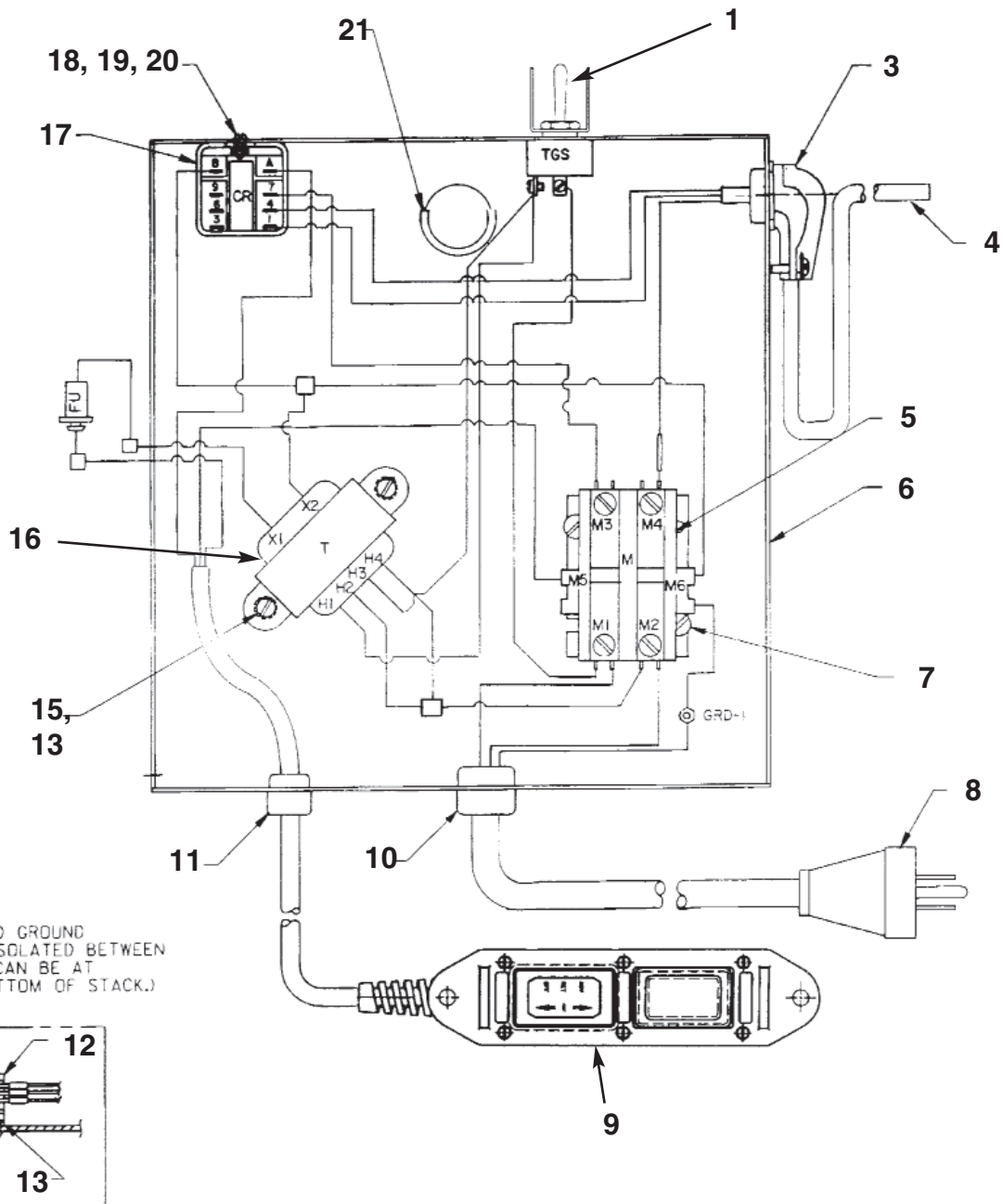
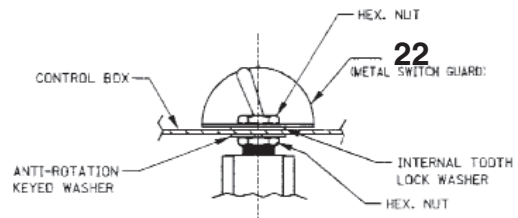
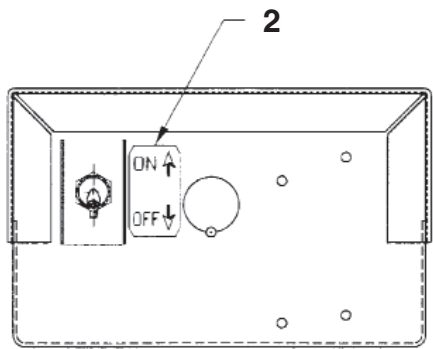

POWER CORD GROUND
(MUST BE ISOLATED BETWEEN
NUTS AND CAN BE AT
TOP OR BOTTOM OF STACK.)

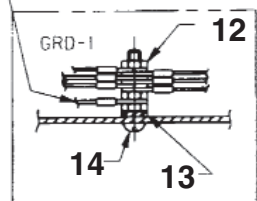

NOTE: SERRATED LOCK WASHER
MUST BE ADJACENT TO
METAL BOX. MORE WASHERS
CAN BE USED IF DESIRED.

Item No.	Part No.	No. Req'd	Description
1	12301	1	Switch
2	205409	1	On/Off Label Decal
3	11144	1	Conduit 90° Connector
4	11911	2.6 ft.	Cord (18/3 SJO)
5	420718-4	1	Contacter
6	51218WH2	1	Electrical Control Box
7	10166	2	Machine Screw (#10-24 X 1/2 Lg.)
8	307440	1	Cord Set
9	250023	1	Remote Hand Switch Assembly (See sheet 8 of 8)
10	210112	1	Strain Relief Bushing
11	15993	1	Strain Relief Bushing
12	10197	2	Hex Nut (10-24)
13	11108	3	Ext. Tooth Washer (.40 x .20)
14	11856	1	Rnd. Hd. Screw (10-24 x 1)
15	11539	2	Sl. Rd. Hd. Machine Screw (#10-24 x 1/4 Lg.)
16	11852	1	Transformer
17	39092	2	Relay
18	10159	2	Sl. Rd. Hd. Machine Screw (#6-32 x 5/16 Lg.)
19	15906	2	Washer
20	10195	2	Machine Screw Nut (#6-32)
21	15497	1	Rubber Grommet
22	352061	1	Metal Switch Guard

ELECTRICAL SCHEMATIC

115 Volt, 50/60 Hz. Single Phase
230 Volt, 50/60 Hz. Single Phase

Note: Shaded areas reflect last revision(s) made to this form.

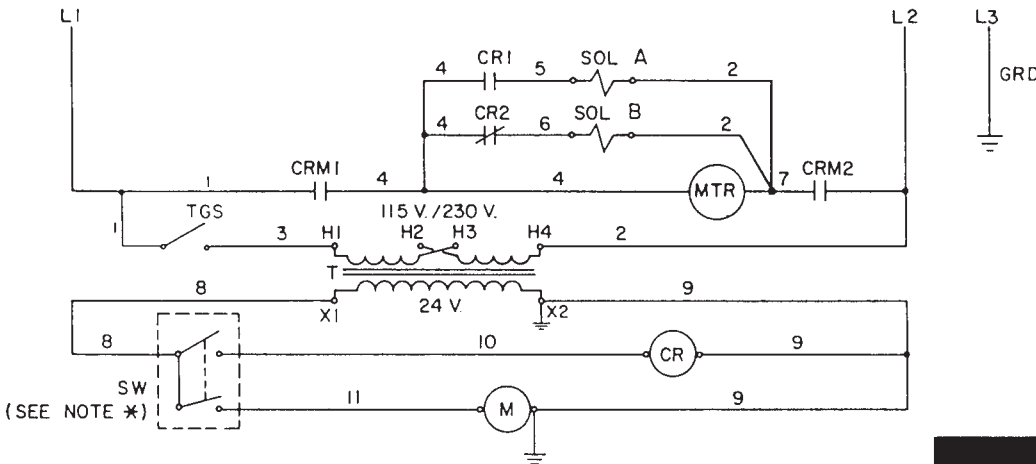

NOTE*
PROGRESSIVE REMOTE CONTROL SWITCH.
POSITION 1 (OFF): MOTOR OFF, SOLENOID OFF.
POSITION 2 (RET.): MOTOR ON, SOLENOID "B" ON.
POSITION 3 (ADV.): MOTOR ON, SOLENOID "A" ON. (MOMENTARY)
MOTOR STAYS ON BETWEEN POSITION 2 AND 3.

TRANSFORMER CONNECTIONS

115 V. 50/60 Hz.	230V. 50/60 Hz.
H1 to TGS-2	H1 to TGS-2
H2 to M2	H2 to H3
H3 to TGS-2	H4 to M2
H4 to M2	

⚠ WARNING

To help avoid personal injury, all electrical work must be done by a qualified electrician.

North American & International Color Codes:

Conductors	North American	International
Line	Black	Brown
Neutral	White	Blue
Ground	Green	Green/Yellow

NOTE: Solenoid wiring; Red wire = 60 Hz., Yellow wire = 50 Hz. system.

GENERAL PUMP ASSEMBLY

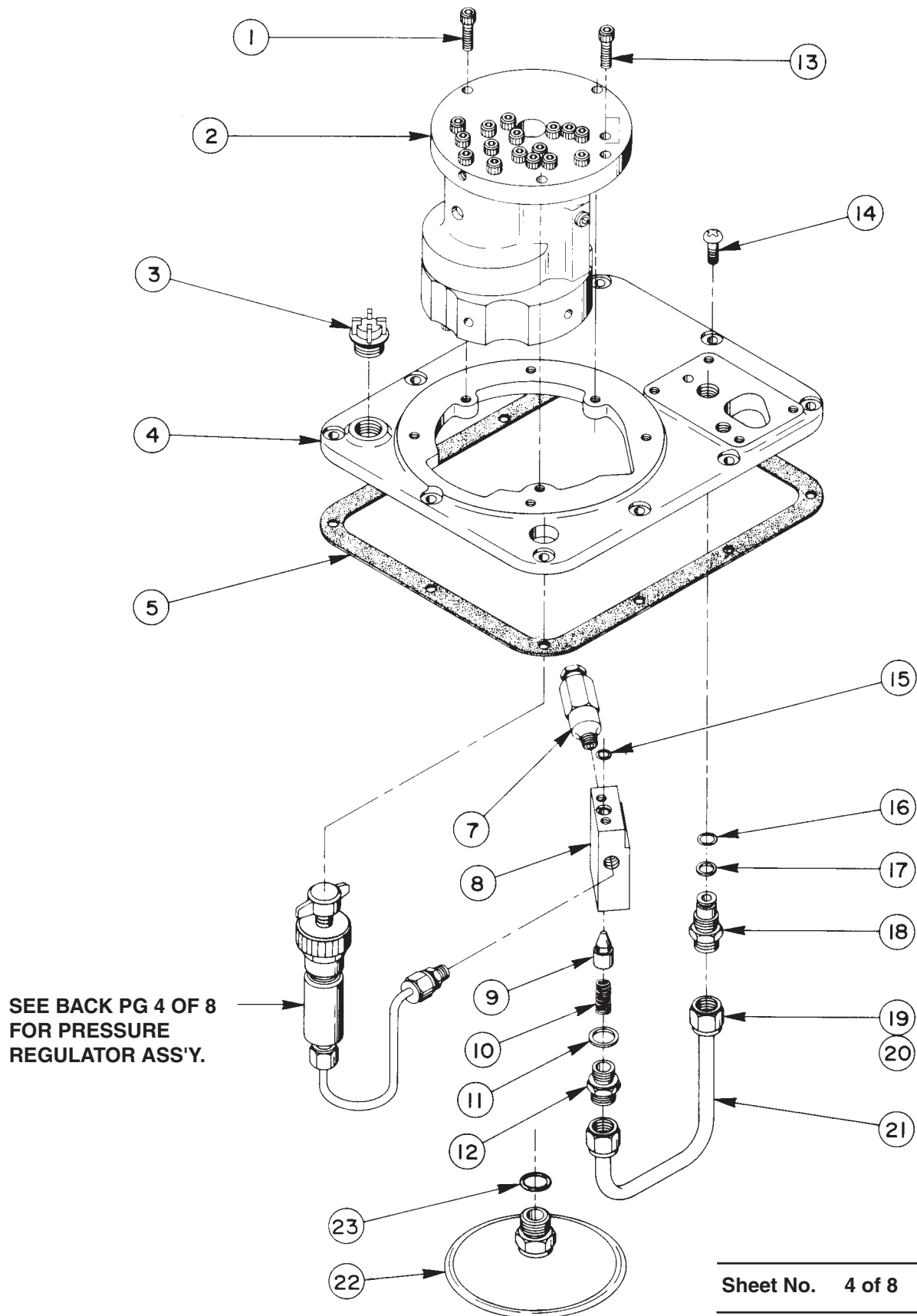

Parts List, Form No. 100581, Back sheet 4 of 8

Item No.	Part No.	No. Req'd	Description
1	10016	3	Soc. Hd. Cap Screw (1/4-20 UNC x 1" Lg.)
2	27207	1	Basic Pump Assembly Replacement (Includes all items on sheet 5 of 8 and items 1, 7, 8, 9, 10, 11, 12, 13, 15, & 22)
3	20937	1	Filler Plug
4	40064WH2	1	Cover
5	40164	1	Gasket
7	21278	1	Relief Valve (Set at 10,000/10,700 PSI)
8	20776	1	Valve Body
9	20771	1	Poppet
10	10425	1	Compression Spring (3/8 I.D. x 3/4 Lg.)
11	10261	1	Copper Washer
12	20770	1	Connector (Torque to 40/45 ft. lbs. oiled)
13	10015	2	Soc. Hd. Cap Screw (1/4-28 UNF x 1" Lg.; Torque to 180 in. lbs.)
14	10177	10	Cap Screw (1/4-10 x 7/8 Lg.)
15	10266	1	O-ring (3/8 x 1/4 x 1/16)
16	10268	1	O-ring (1/2 x 3/8 x 1/16)
17	11863	1	Teflon Backup Washer (1/2 x 3/8 x 1/16)
18	20787	1	Valve Connector
19	10430	2	Tube Sleeve
20	10431	2	Tube Nut
21	21045	1	Oil Line
22	21344	1	Filter Assembly (Includes Item #23)
23	10300	1	O-ring (5/8 x 15/32 x 5/64)

PRESSURE REGULATOR ASSEMBLY

NOTE: Set at 9,800/10,000 PSI

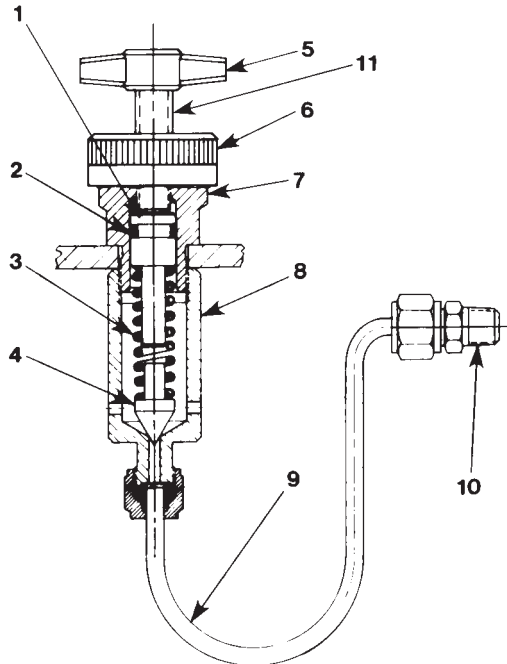

Item No.	Part No.	No. Req'd	Description
1	21306	1	Spring Guide
2	10268	1	O-ring (1/2 x 3/8 x 1/16)
3	10495	1	Compression Spring (15/32 O.D. x 1-5/8 Lg.)
4	21046	1	Valve Stem
5	205788	1	Thumbscrew
6	24573	1	Knob Locknut
7	21305	1	Valve Cap
8	22361	1	Body
9	29267	1	Oil Line Assembly
10	14844	1	Connector
11	208148	1	Soc. Hd. Cap Screw (3/8-24 UNF x 1-1/2 Lg.)

BASIC PUMP ASSEMBLY

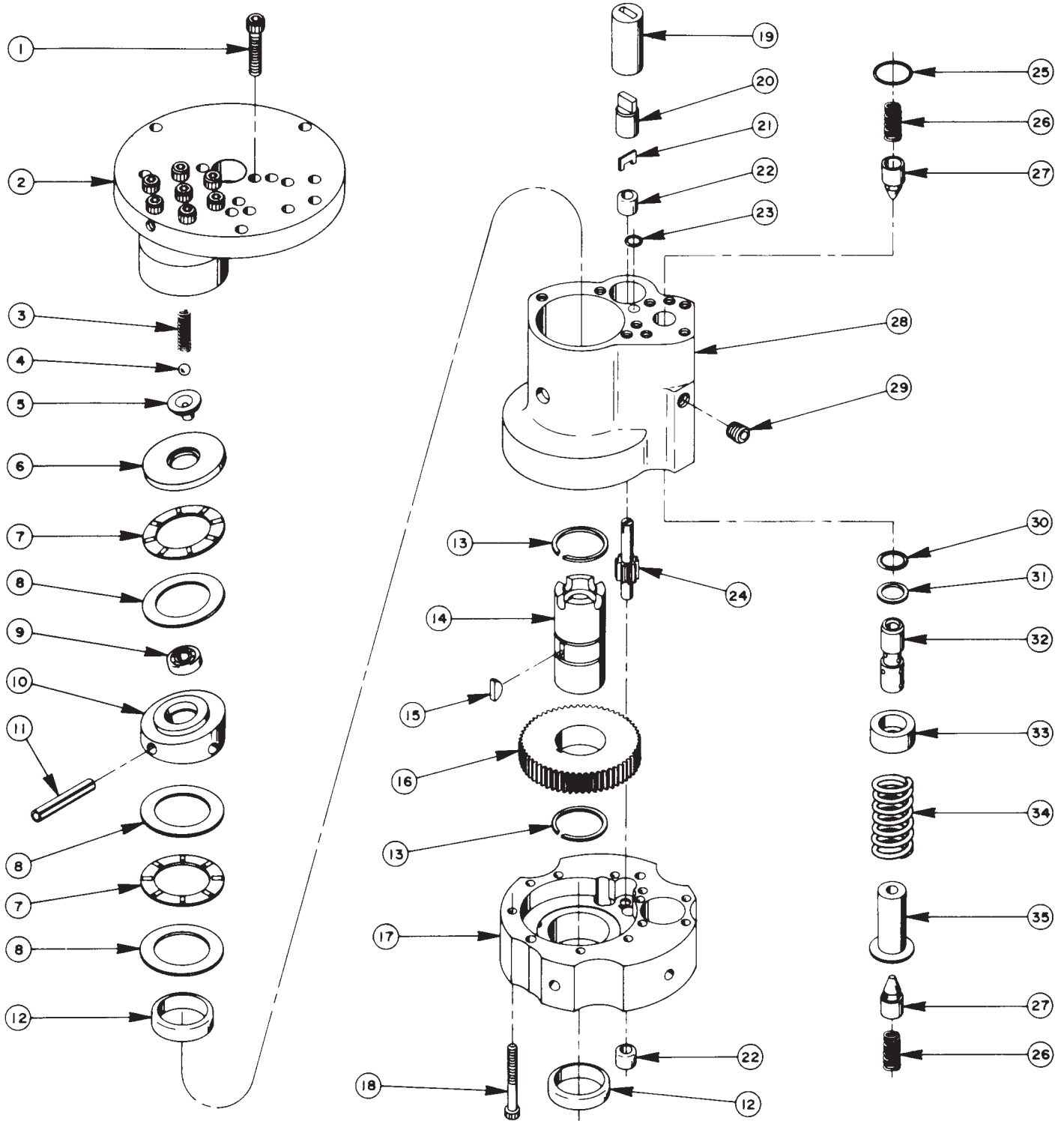

Item No.	Part No.	No. Req'd	Description
1	10020	9	Soc. Hd. Cap Screw (1/4-20 UNC x 1-1/4 Lg.; Torque to 170-180 in. lbs.)
2	33113	1	High Pressure Pump Assembly (See sheet 6 of 8)
3	10361	1	Compression Spring (1/4 O.D. x 1" Lg.)
4	10375	1	Steel Ball (1/4 dia.)
5	23547	1	Bearing Top Plate
6	23548	1	Top Plate
7	11228	2	Thrust Bearing
8	11813	3	Bearing Race
9	11814	1	Ball Bearing
10	23549	1	Angle Plate
11	11955	1	Roll Pin (1/4 dia. x 1-3/4 Lg.)
12	11064	2	Needle Bearing
13	11261	2	Retaining Ring
14	23556	1	Shaft
15	11821	1	Woodruff Key
16	23574	1	Gear
17	40072	1	Pump End Plate
18	10001	13	Soc. Hd. Cap Screw (#10-32 UNF x 1-3/4 Lg.; Torque to 50 in. lbs.)
19	21091	1	Aluminum Coupling
20	21092	1	Adapter
21	21093	1	Key
22	11198	2	Needle Thrust Bearing (See diagram below)
23	10266	1	O-ring (3/8 x 1/4 x 1/16)
24	20774	1	Drive Gear
25	10303	1	O-ring (7/8 x 3/4 x 1/16)
26	10425	2	Compression Spring (3/8 O.D. x 3/4 Lg.)
27	20771	2	Poppet
28	40071	1	Pump Body
29	10427	1	Pipe Plug (1/8 NPTF)
30	10271	1	O-ring (11/16 x 1/2 x 3/32)
31	12389	1	Teflon Backup Washer
32	20849	1	Spool
33	23255	1	Spring Guide
34	10426	1	Compression Spring (5/8 I.D. x 1-3/4 Lg.)
35	23256	1	Spring Guide

NEEDLE BEARING INSTALLATION SPECIFICATIONS

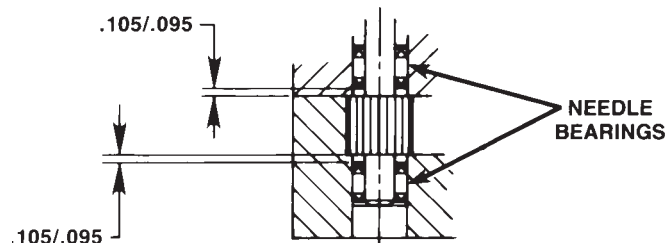

When replacing the needle bearings on the drive gear of the basic pump, the dimensions shown must be as specified.

HIGH PRESSURE PUMP ASSEMBLY

See Diagram
on Reverse
Side for
Important
Ass'y
Information

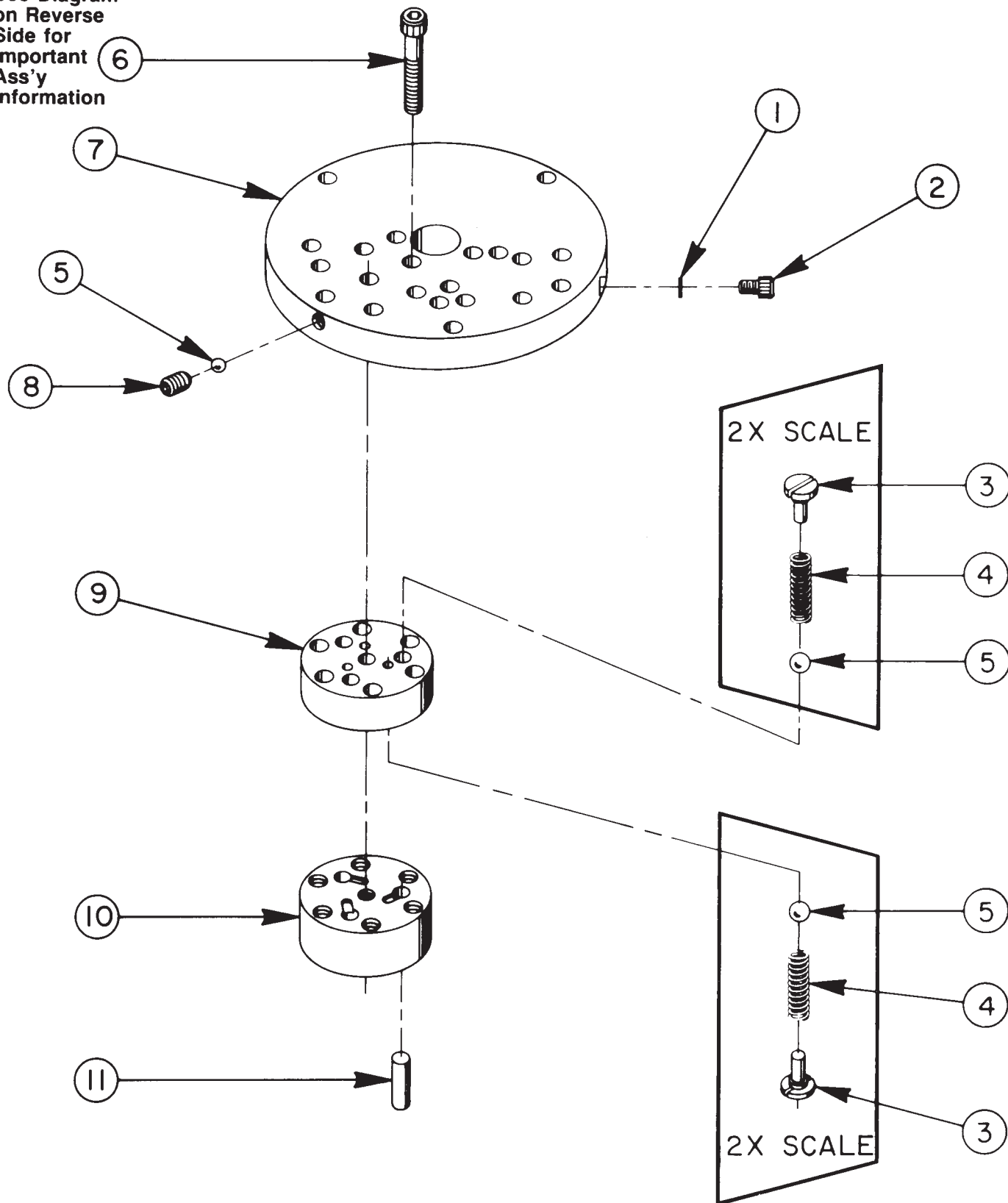

33113 HIGH PRESSURE PUMP ASSEMBLY

3 Pistons --- 9/32 Dia.

Item No.	Part No.	No. Req'd	Description
1	10442	1	Copper Washer
2	10002	1	Soc. Hd. Cap Screw (1/4-20 UNC x 3/8 Lg.; Torque to 140/160 in. lbs.)
3	*24549	6	Valve Guide
4	*10445	6	Compression Spring (5/32 O.D. x 3/4 Lg.)
5	*12223	7	Steel Ball (3/16 dia.)
6	*10023	7	Soc. Hd. Cap Screw (1/4-28 UNF x 1-1/2 Lg.; Torque to 170/180 in. lbs.)
7	*50411	1	Top Plate
8	10519	1	Soc. Set Screw (Torque to 65/70 in. lbs.)
9	*40630	1	Valve Head
10	*41062	1	Pump Barrel
11	*21628	3	Piston

Consult factory when replacing items marked with an asterisk (*).

BOLT TIGHTENING SEQUENCE

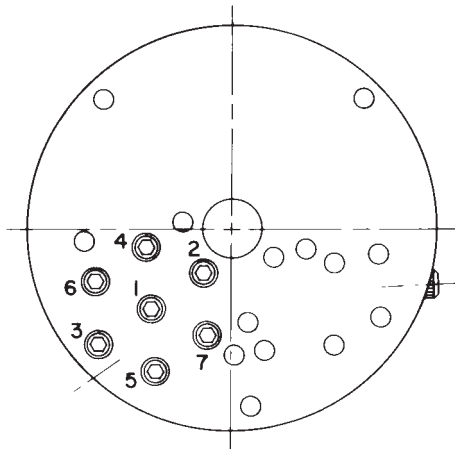

NOTE: Assemble in sequence shown.
Lubricate under head and on threads.
Torque to 170/180 in. lbs.

VALVE ASSEMBLY

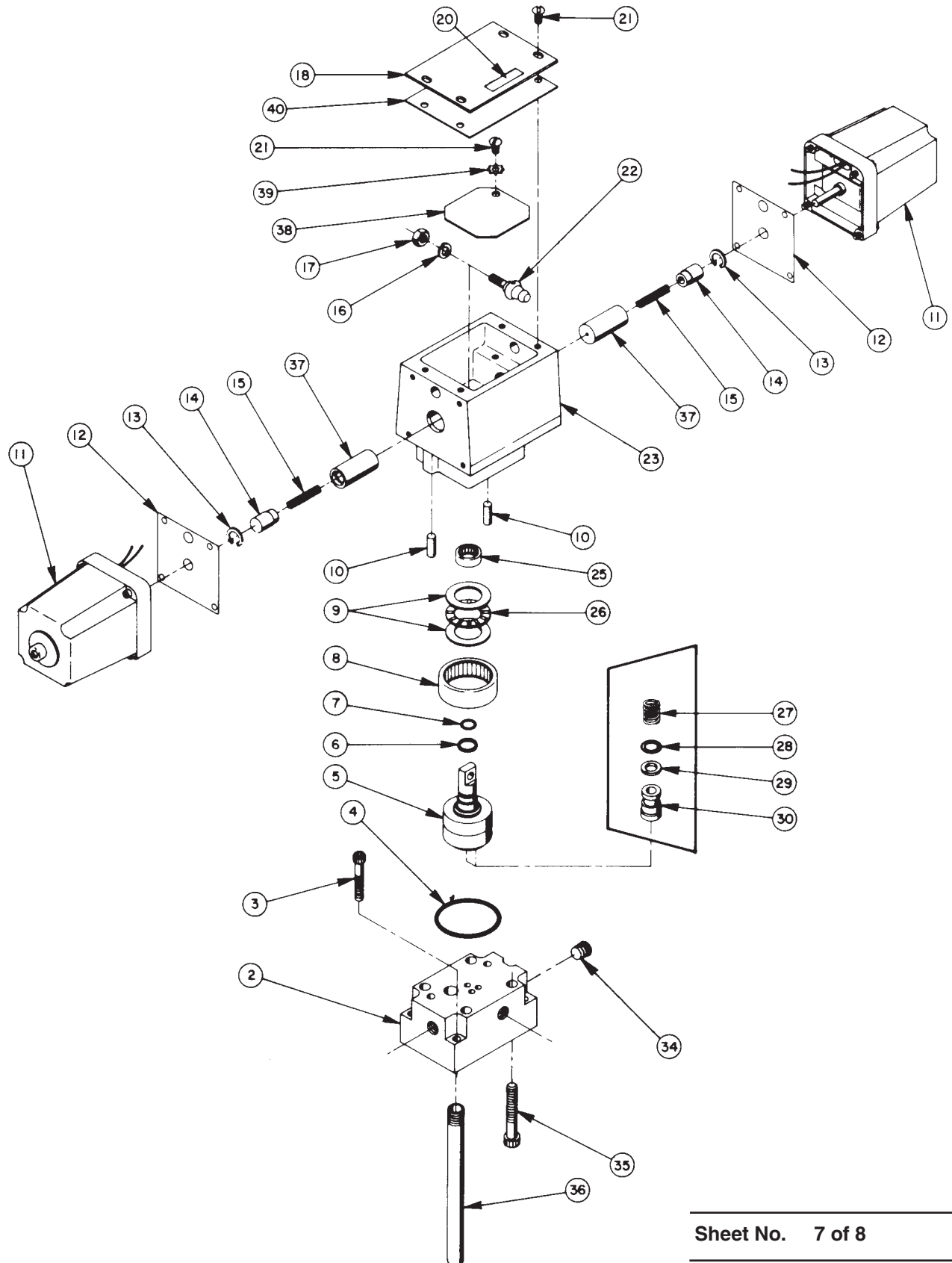

Parts List, Form No. 100581, Back sheet 7 of 8

Item No.	Part No.	No. Req'd	Description
2	61078	1	Subplate
3	10022	4	Soc. Hd. Machine Screw (1/4-20 UNC x 1-1/2 Lg.)
4	*214699	1	O-ring (2-3/16 x 2" x 3/32)
5	52064	1	Rotor
6	*208672	1	Glyd Ring
7	*10268	1	O-ring (1/2 x 3/8 x 1/16)
8	17505	1	Needle Roller Bearing
9	15935	2	Thrust Washer
10	17567	2	Spring Pin
11	304068	2	Solenoid (115 V., 60 Hz.; For SST-10)
	304069	2	Solenoid (230 V., 50/60 Hz.; For SST-20)
	350091	2	Solenoid (100 V., 50/60 Hz.; For SST-100)
	350201	2	Solenoid (200 V., 50/60 Hz; For SST-200)
12	303980	2	Stop Plate
13	11522	2	Retaining Ring
14	208590	2	Spring Guide
15	13960	2	Compression Spring (1/4 O.D. x 1-1/2 Lg.)
16	10245	1	Lockwasher
17	15504	1	Locknut (1/4-28)
18	303976	1	Cover
20	209383	1	Patent Decal
21	10164	5	Machine Screw (#10-24 UNC x 3/8 Lg.)
22	304030	1	Lever
23	61077	1	Valve Body
25	208671	1	Needle Roller Bearing
26	12188	1	Roller Bearing
27	15095	2	Compression Spring (1/4 O.D. x 1/2 Lg.)
28	*10265	2	O-ring (5/16 x 3/16 x 1/16)
29	*15174	2	Backup Washer (5/16 x 3/16 x 3/64)
30	303935	2	Shear Seal
34	10479	1	Pipe Plug (1/4 NPTF)
35	18328	4	Soc. Hd. Cap Screw (5/16-18 UNC x 2" Lg.; Torque to 300/400 in. lbs.)
36	200609	1	Drain Tube
37	303968	2	Actuator Plunger
38	303977	1	Inner Cover
39	11108	1	Lockwasher
40	303986	1	Cover Gasket

PARTS INCLUDED BUT NOT SHOWN

13888	1	Straight Fitting
15499	1	Pipe Plug (1/8 NPTF; For SST-100 & SST-200)
16797	1	Elbow Fitting (For SST-100 & SST-200)

REMOTE HAND SWITCH ASSEMBLY #250023

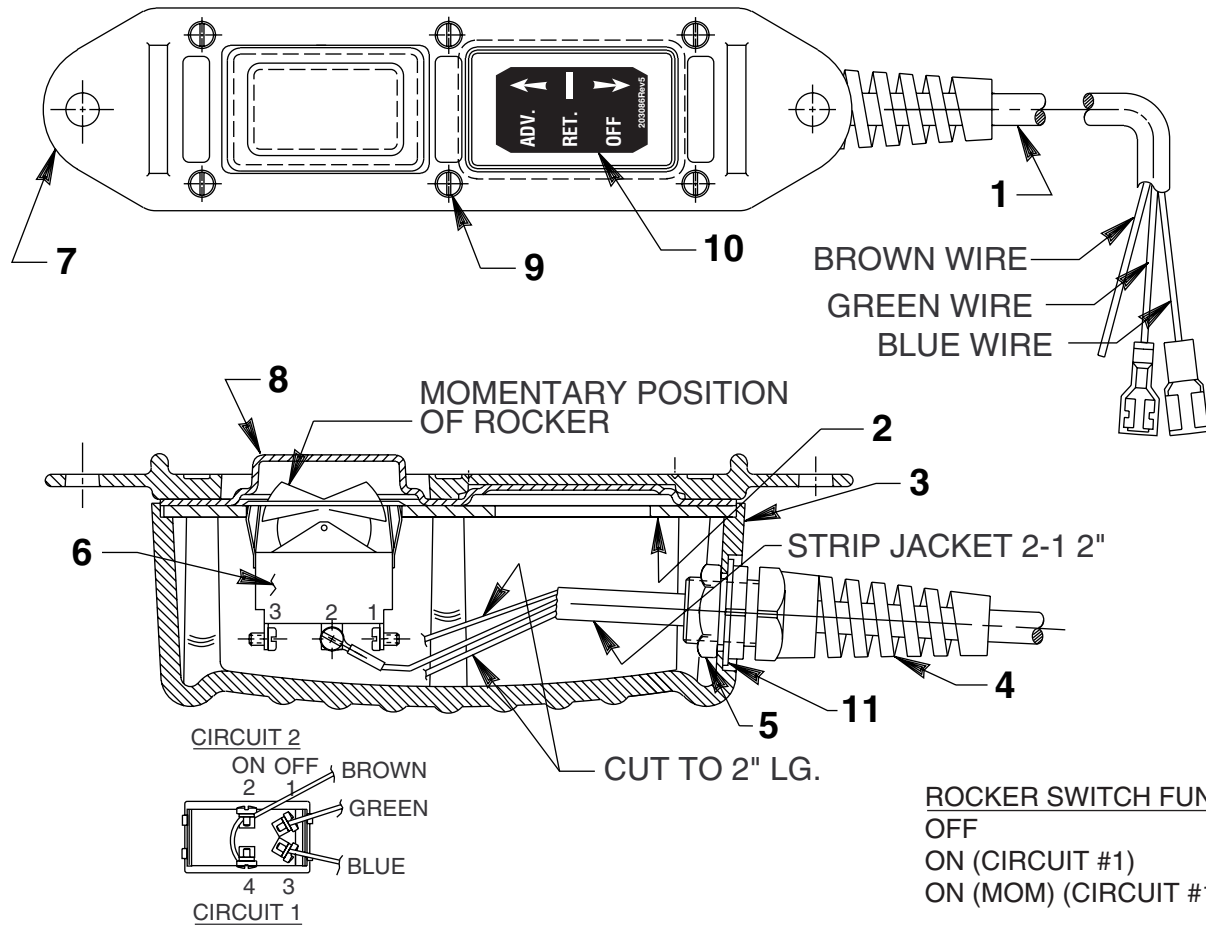

Item No.	Part No.	No. Req'd	Description
1	12908	21 ft.	Cable (18/3 SJTO)
2	420050-3	1	Switch Mounting Plate
3	420050-4	1	Switch Mounting
4	251818	1	Strain Relief Connector
5	251802	1	Locknut (Torque to 30/35 in. lbs.)
6	420017	1	Rocker Switch

Item No.	Part No.	No. Req'd	Description
7	420050-1	1	Cover
8	420050-2	1	Gasket
9	250248	6	Screw (4-24 x 3/4 Lg.)
10	203086	1	Decal
11	253607	1	Gasket