

MODEL D HYDRAULIC PUMP AIR DRIVEN WITH REMOTE CONTROL GENERAL ASS'Y SIDE VIEW

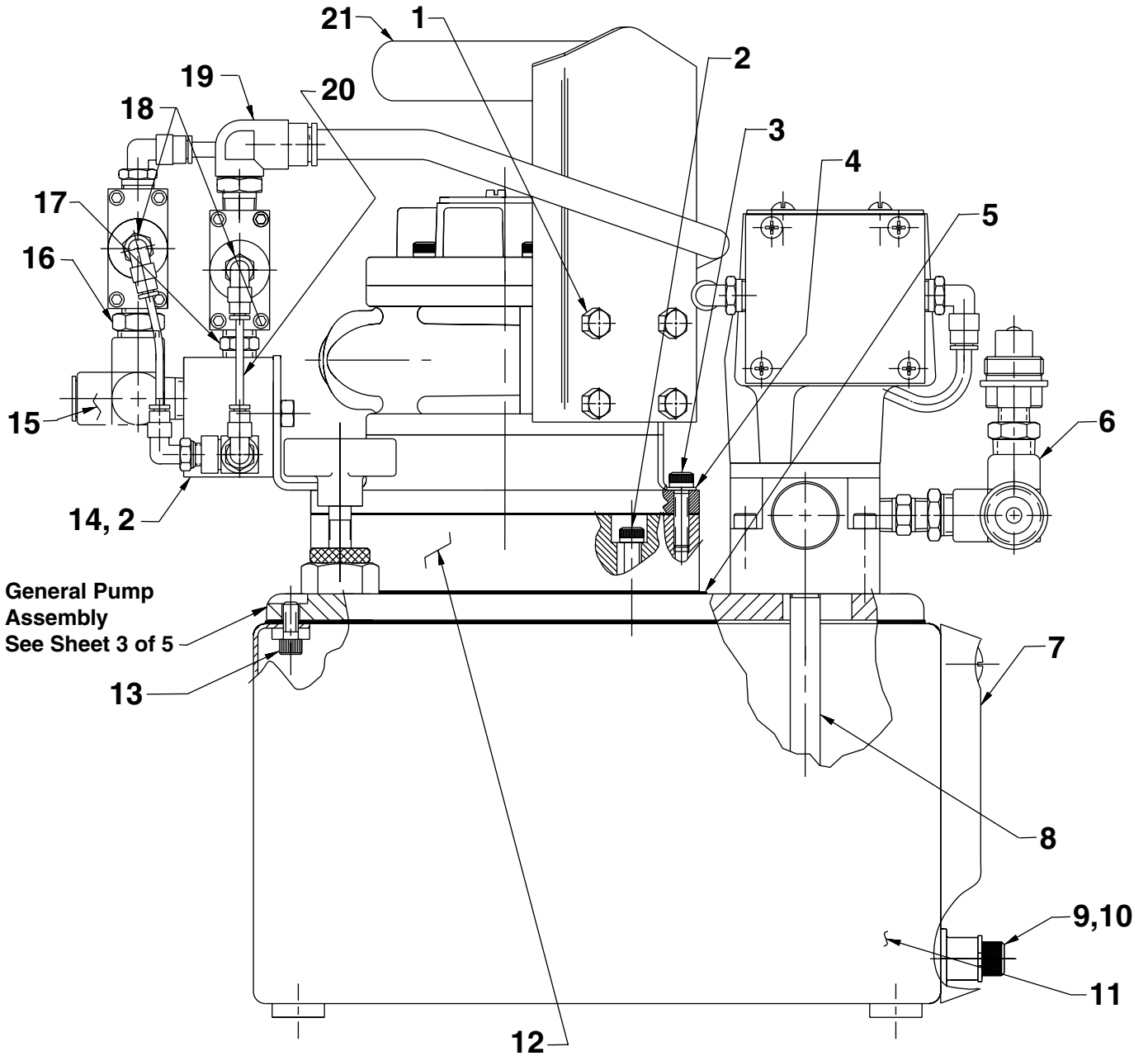

Part List, Form No. 108184, Back sheet 1 of 5

Item No.	Part No.	No. Req'd	Description
1	10005	4	Cap Screw (1/4-20 x 1/2)
2	10022	6	Soc.Hd. Screw (1/4-20 x 1 1/2)
3	10016	3	Soc.Hd. Screw (1/4-20 x 1)
4	10244	3	Lock Washer (.49 x .26)
5	30650	1	Motor Base Gasket
6	351076	1	Tee Assembly
7	350431	1	Oil Level Gauge (w/thermometer)
8	200609	1	Drain Tube
9	10412	1	Soc.Hd. Screw (3/8-16 x 1/2)
10	19779	1	Seal Washer (.73 x .42)
11	64364BK2	1	Reservoir

Item No.	Part No.	No. Req'd	Description
12	422056	1	Motor Base
13	10006	1	Soc Hd Screw (1/4-20 x 5/8)
14	350244	1	Manifold
15	10623	1	Tee Fitting (3/8 NPTF)
16	12328	1	Straight Fitting (1/4 NPTF)
17	16494	1	Straight Fitting (1/8 NPTF)
18	250804	1	90° Elbow Fitting
19	252297	1	90° Elbow Fitting
20	14281	.8 Ft.	Nylon Tubing
21	422102BK2	1	Weldment Handle

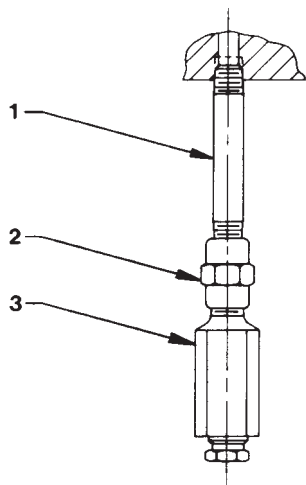

PRESSURE CONTROL VALVE

NOTE: Set at 1500/1700 PSI

Item No.	Part No.	No. Req'd	Description
1	15456	1	Nipple Fitting
2	18841	1	Straight Fitting
3	21278-15	1	Relief Valve Ass'y

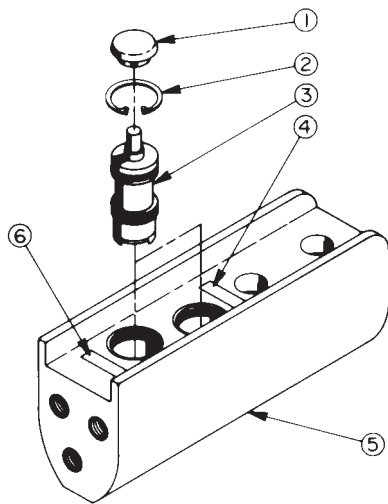

HAND CONTROL ASSEMBLY

Item No.	Part No.	No. Req'd	Description
1	206105	2	Push Button
2	11033	2	Retaining Ring
3	206104	2	Valve Cartridge (Including seals)
4	203769	2	Decal (Stop)
5	421265	1	Control Valve Body (Includes decals [Items 4 & 6])
6	203770	1	Decal (Run)

GENERAL ASS'Y TOP VIEW

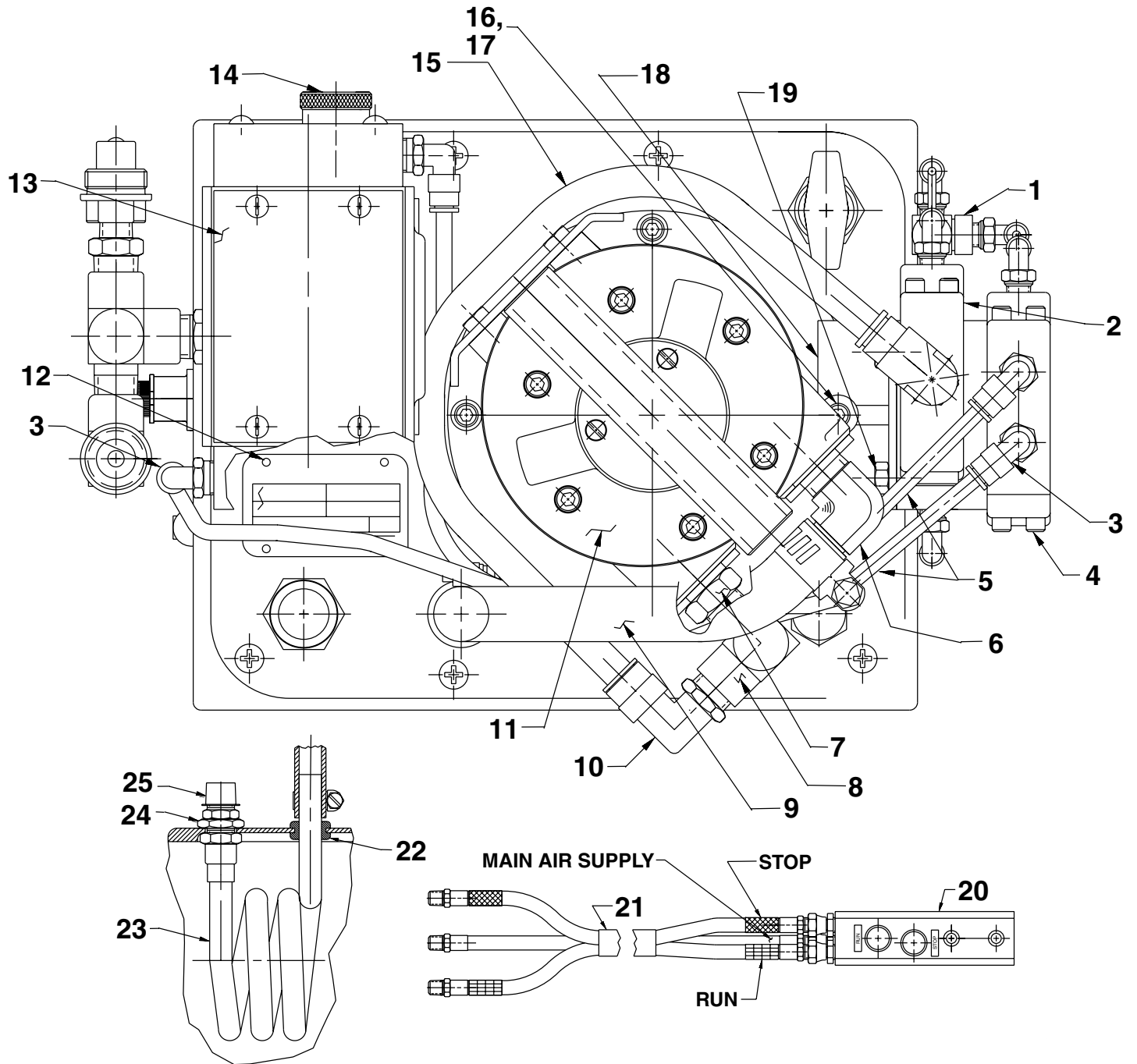

Parts List, Form No. 108184, Back sheet 2 of 5

Item No.	Part No.	No. Req'd	Description
1	19463	1	Tee Fitting (1/8 NPTF)
2	360131	1	Air Operated Valve
3	15457	4	90° Elbow Fitting (1/4 NPTF)
4	360132	1	Air Operated Valve
5	15883	2.8ft.	Polyethylene Tubing
6	212897	1	90° Elbow Fitting (1/2 NPTF)
7	250260	1	Straight Fitting 1/2 NPTF)
8	10621	1	90° Elbow Fitting (3/8 NPTF)
9	212898	.9ft.	Pressure Hose
10	253490	1	90° Elbow Fitting
11	66484	1	Air Motor (See Form No. 108171)
12	10575	4	Drive Screw (2 x 3/16)
13	66209	1	Air Valve (4 Way Pump Mount; See Form No. 108100)
14	251797	1	Quick Coupler
15	252296	1.67ft.	Nylon Tubing
16	10020	1	Soc Hd Screw (1/4-20 x 1-1/4)
17	12719	1	Plain Washer (.63 x .29)
18	360135BK2	1	Weldment Handle
19	10199	2	Hex Nut (1/4-20)
20	421265	1	Air Operated Hand Control (See back sheet 1 of 5)
21	420096	1	Hose Assembly (25' Lg.)
22	212896	1	Rubber Grommet
23	46626	1	Heat Exchanger Coil
24	251796	1	Hex Jam Nut
25	251795	1	Straight Fitting

GENERAL PUMP ASSEMBLY

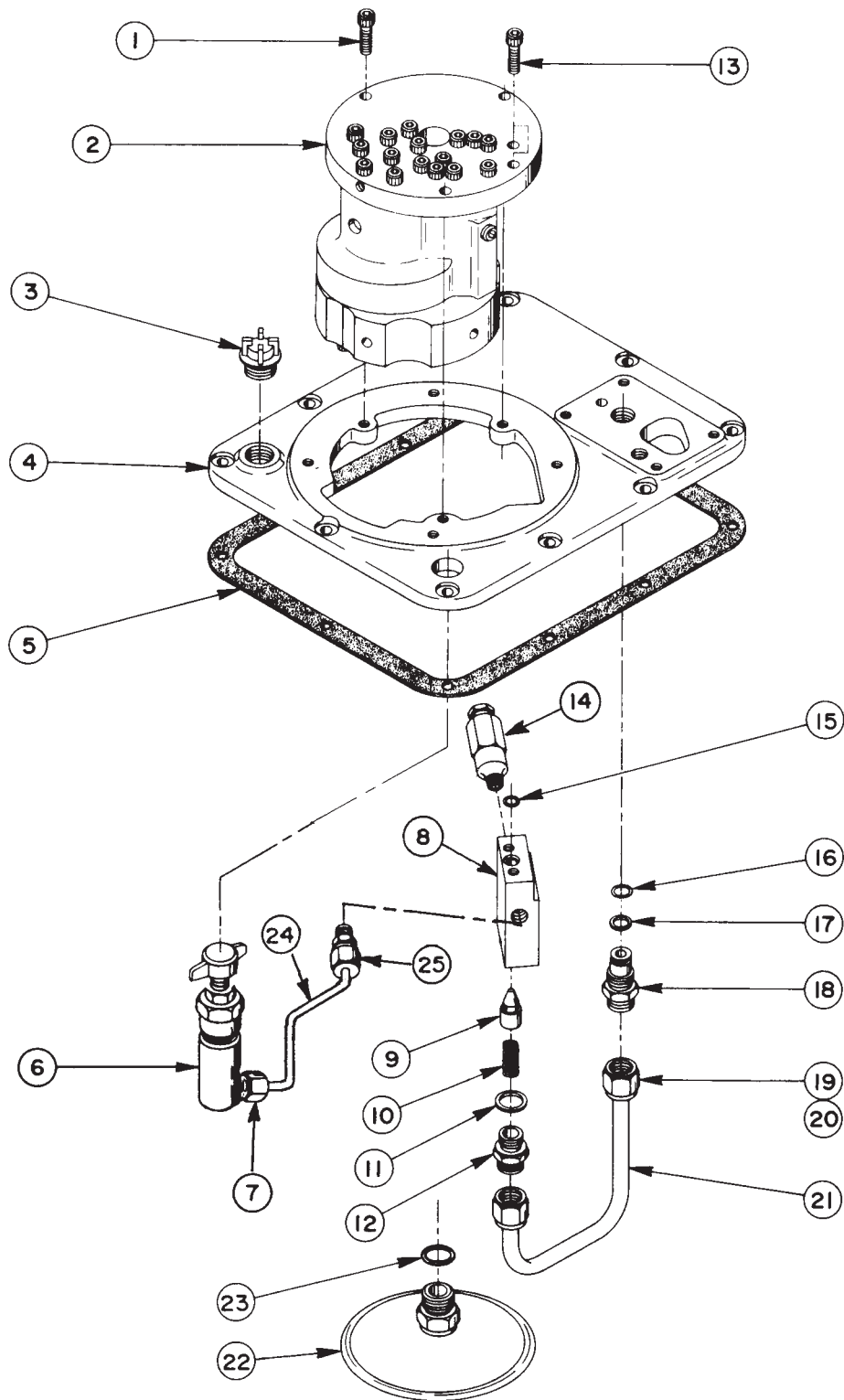

Parts List, Form No. 108184, Back sheet 3 of 5

Item No.	Part No.	No. Req'd	Description
1	10016	3	Cap Screw (1/4-20 X 1" Lg.)
2	-----	1	Basic Pump Assembly (Includes all items on sheet 4 of 5 and items 1, 7, 8, 9,10, 11, 12, 13, 15 & 22 on this sheet)
3	20937	1	Vent Cap
4	46627WH2	1	Cover
5	40164	1	Gasket
6	47647	1	External Pressure Regulator (See below)
7	16177	1	90° Elbow Fitting
8	20776	1	Valve Body
9	20771	1	Poppet
10	10425	1	Comp. Spring (3/8 O.D. X 3/4 Lg.)
11	10261	1	Copper Washer (3/4 X 19/32 X 1/32)

Item No.	Part No.	No. Req'd	Description
12	20770	1	Connector (Torque to 40/45 in. lbs.)
13	10015	2	Cap Screw (1/4-28 X 1" Lg.; Torque to 180 in. lbs.)
14	21278	1	Relief Valve (Set at 10,100/10,700 PSI)
15	10266	1	O-ring (1/4 X 3/8 X 1/16)
16	10268	1	O-ring (1/2 X 3/8 X 1/16)
17	11863	2	Teflon Backup Washer
18	20787	1	Valve Connector
19	10430	2	Tube Sleeve
20	10431	2	Tube Nut
21	21045	1	Oil Line
22	21345	1	Filter Ass'y (Includes Item #23)
23	10527	1	O-ring (13/16 X .644 X .087)
24	201570	1	Oil Line Tube
25	14844	1	Straight Fitting

PRESSURE REGULATOR ASSEMBLY

NOTE: Set at 10,100/10,700 PSI

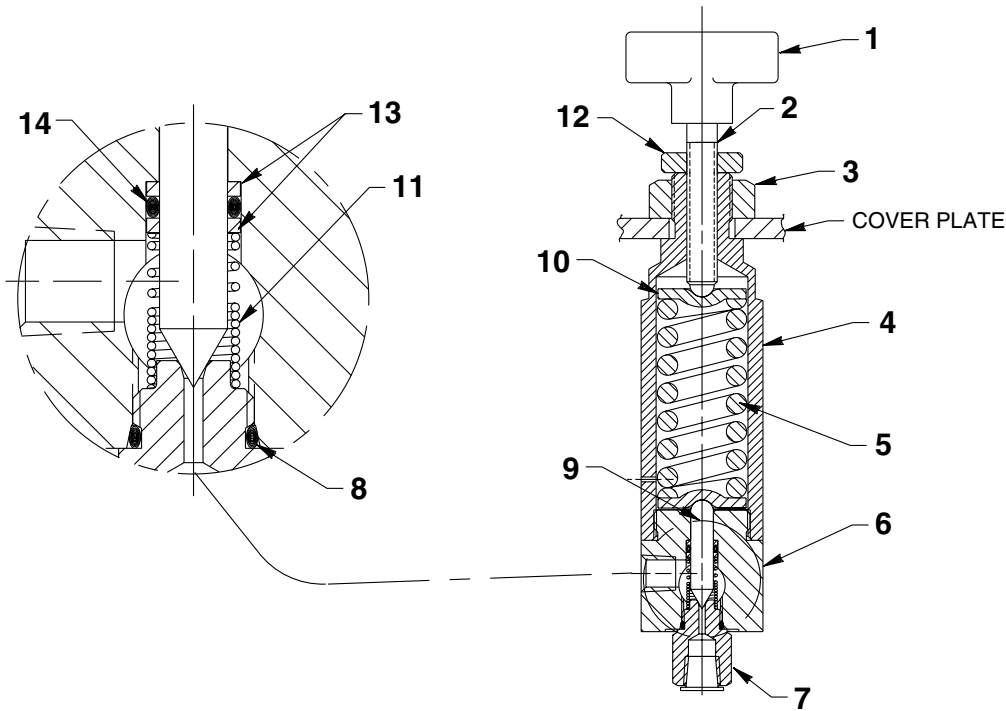

Item No.	Part No.	No. Req'd	Description
1	215693	1	Knob
2	215721	1	Adjustment Stem (Assemble to knob with Loctite No. 242 or equiv.)
3	10396	1	Jam Nut
4	309077	1	Regulator Housing
5	215429	1	Compression Spring (1.100 O.D. X 2-1/2 Lg.)
6	47648	1	Regulator Body
7	309078	1	Seat Fitting
8	13755	1	O-ring (.558 x .414 x .072)

Item No.	Part No.	No. Req'd	Description
9	309079	1	Poppet
10	215428	2	Spring Retainer (Grease pocket [both ends] before assembly)
11	215431	1	Spring (Assemble closed coils of spring form towards seat fitting [Item #7])
12	21583	1	Locknut
13	215430	2	Backup Washer
14	10266	1	O-ring (3/8 X 1/4 X 1/16)

BASIC PUMP ASS'Y

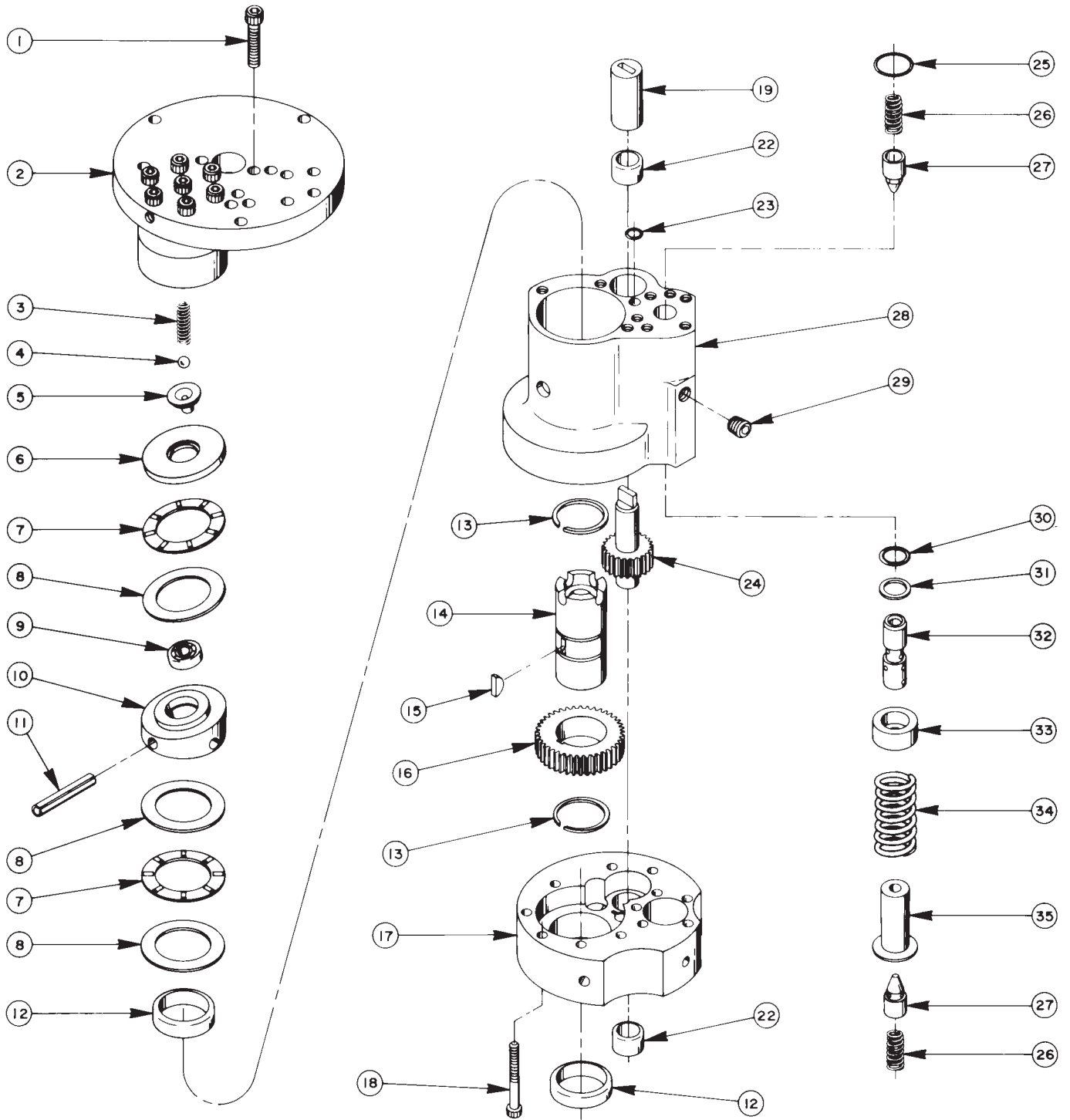

Item No.	Part No.	No. Req'd	Description
1	10020	9	Soc. Hd. Cap Screw (1/4-20 X 1-1/4 Lg.; Torque to 170-180 in. lbs.)
2	33113	1	High Pressure Pump Ass'y (See back sheet 5 of 5)
3	10361	1	Compression Spring (1/4 O.D. X 1" Lg.)
4	10375	1	Steel Ball (1/4 Dia.)
5	23547	1	Bearing Top Plate
6	23548	1	Top Plate
7	11228	2	Thrust Bearing
8	11813	3	Bearing Race
9	11814	1	Ball Bearing
10	23549	1	Angle Plate
11	11955	1	Roll Pin (1/4 Dia. X 3/4 Lg.)
12	11064	2	Needle Bearing
13	11261	2	Retaining Ring (1-1/8 Shaft)
14	23556	1	Shaft
15	11821	1	Woodruff Key
16	23557	1	Gear
17	30533	1	Pump End Plate
18	10001	12	Soc. Hd. Cap Screw (10-32 X 1-3/4 Lg.; Torque to 50 in. lbs.)
19	252108	1	Coupling
20	11199	2	Needle Thrust Bearing (See diagram below)
23	10266	1	O-ring (1/4 X 3/8 X 1/16)
24	21272	1	Drive Gear
25	10303	1	O-ring (7/8 X 3/4 X 1/16)
26	10425	2	Compression Spring (3/8 O.D. X 3/4 Lg.)
27	20771	2	Poppet
28	40120	1	Pump Body
29	10427	1	Pipe Plug (1/8 NPTF)
30	10271	1	O-ring (11/16 x 1/2 X 3/32)
31	12389	1	Teflon Backup Washer (11/16 X 1/2 X 1/16)
32	20849	1	Spool
33	23255	1	Spring Guide
34	10426	1	Compression Spring (1" O.D. X 1-13/16 Lg.)
35	23256	1	Spring Guide

NEEDLE BEARING INSTALLATION SPECIFICATIONS

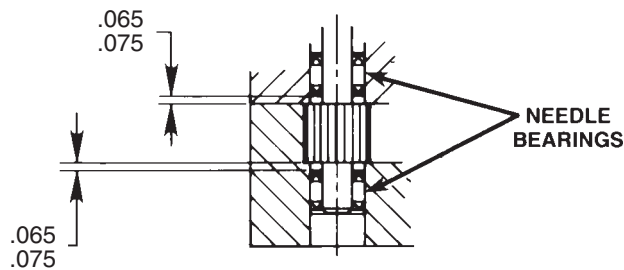

When replacing the needle bearings on the drive gear of the basic pump, the dimensions shown must be as specified.

Note: Shaded areas reflect last revision(s) made to this form.

HIGH PRESSURE PUMP ASSEMBLY

See Diagram on Reverse Side for Important Ass'y. Information

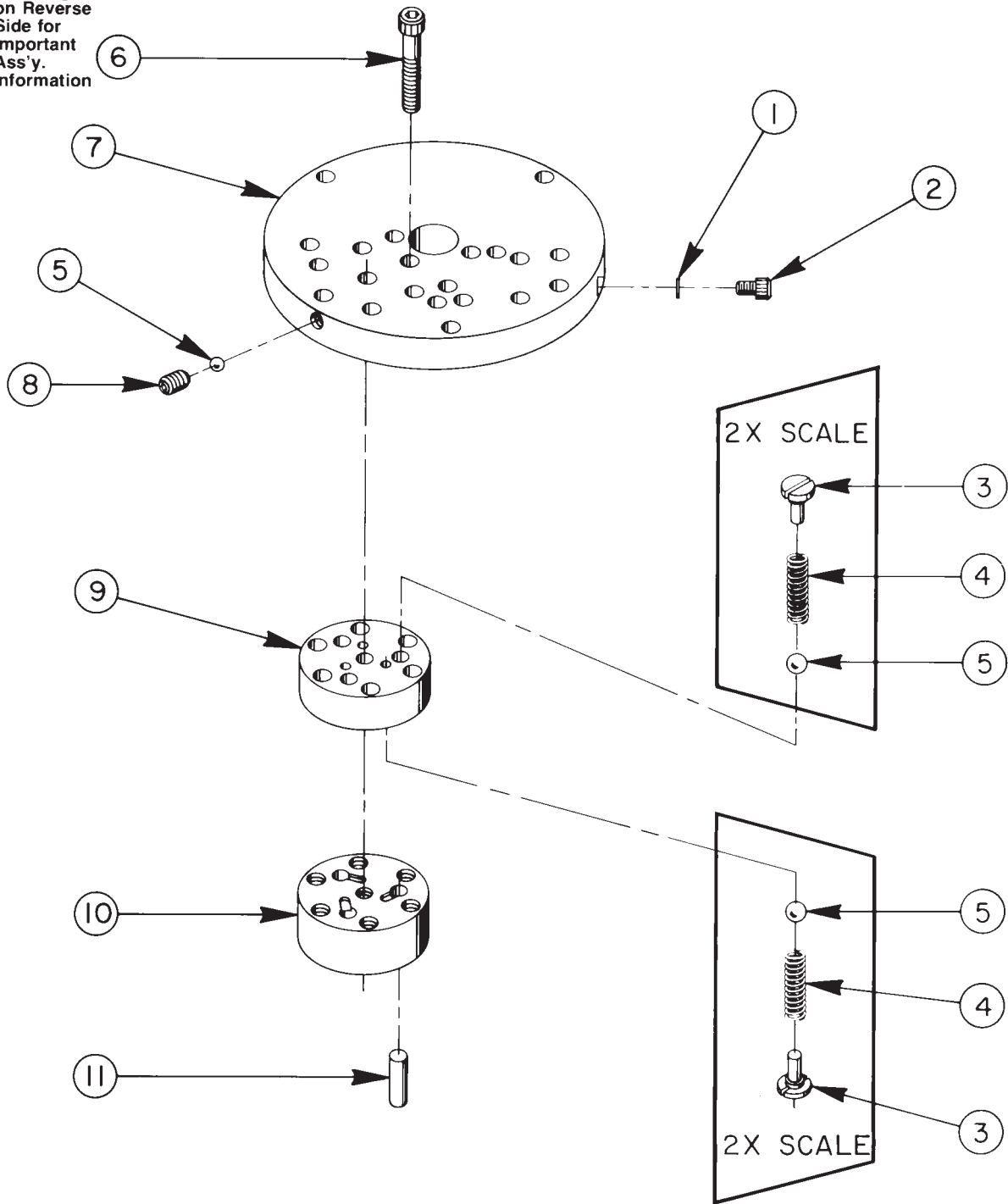

#33113 HIGH PRESSURE PUMP ASS'Y
(3 Pistons - 9/32 Dia.)

Item No.	Part No.	No. Req'd	Description
1	10442	1	Copper Washer (3/8 X 1/4 X 1/32)
2	10002	1	Soc. Hd. Cap Screw (1/4-20 NC X 3/8 Lg.; Torque to 140/160 in. lbs.)
3	*24549	6	Valve Guide
4	*10445	6	Compression Spring (.164 O.D. X .718 Lg.)
5	*12223	7	Steel Ball (3/16 Dia.)
6	*10023	7	Soc. Hd. Cap Screw (1/4-28 NF X 1-1/2 Lg.; Torque to 170/180 in. lbs.)
7	*50411	1	Top Plate (Aluminum)
8	10519	1	Soc. Set Screw (1/4-20 NC X 3/8 Lg.; Torque to 65/70 in. lbs.)
9	*40630	1	Valve Head
10	*41062	1	Pump Barrel
11	*21628	3	Piston

Consult factory when replacing items marked with an asterisk (*).

BOLT TIGHTENING SEQUENCE

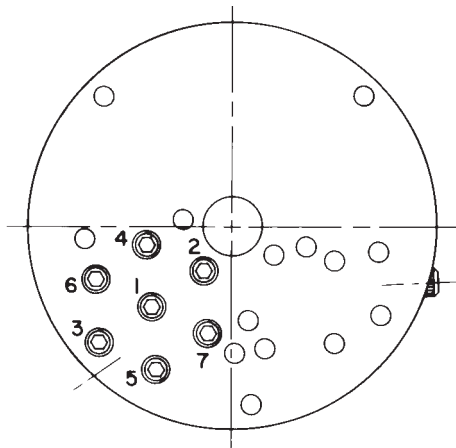

NOTE: Assemble in sequence shown. Lubricate under head and on threads. Torque to 180 in. lbs.

Refer to any operating instructions included with this product for detailed information about operation, testing, disassembly, reassembly, and preventive maintenance.

Items found in this parts list have been carefully tested and selected. **Therefore: Use only genuine Power Team replacement parts!**

Additional questions can be directed to our Technical Services Department.