



HYTORC

DIVISION UNEX CORPORATION

333 STATE Rte. 17 NORTH
MAHWAH, NJ 07430-9895
Tel: (201) 512-9500
Fax: (201) 512-9615

Parts List for:

Form No. 108152

HYTORCQAS-115

**MODEL B
ELECTRIC HYDRAULIC PUMP**

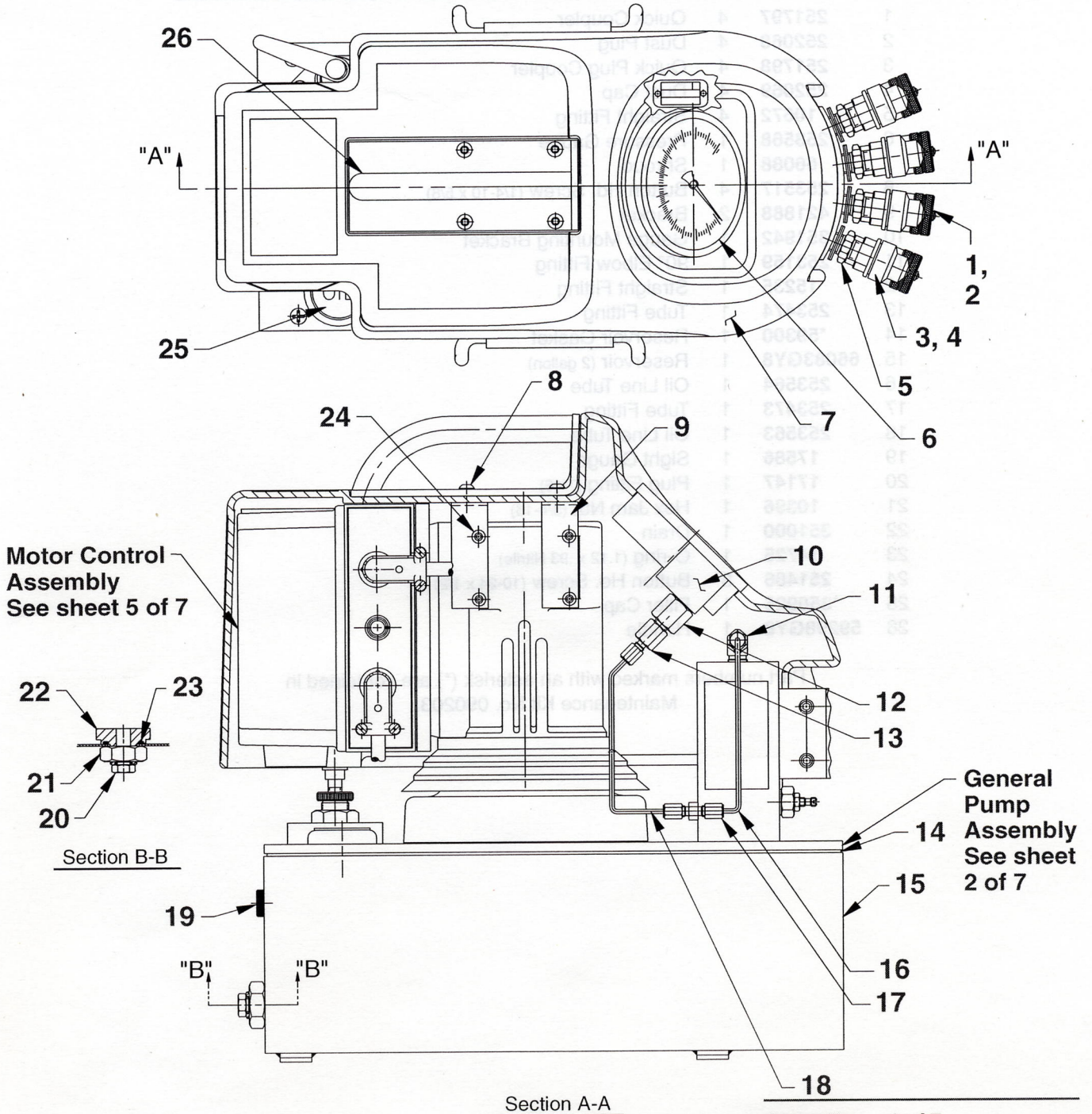

Section A-A

Section B-B

Sheet No. 1 of 7

Rev. Date: 27 Sept. 2000

Parts List, Form No. 108152, Back sheet 1 of 7

HYTORCO
 DIVISION UTEX CORPORATION
 333 STATE ST. LYNNHILL
 MAHWAH, NJ 07430-9882
 Tel (201) 215-9500
 Fax (201) 215-9812

Item No.	Part No.	No. Req'd	Description
1	251797	4	Quick Coupler
2	252068	4	Dust Plug
3	251798	4	Quick Plug Coupler
4	252069	4	Dust Cap
5	10672	4	Straight Fitting
6	253568	1	Pressure Gauge
7	66088	1	Shroud
8	253517	4	Button Hd. Screw (1/4-10 x 5/8)
9	421888	2	Bracket
10	351942	1	Gauge Mounting Bracket
11	253159	1	90° Elbow Fitting
12	15235	1	Straight Fitting
13	253474	1	Tube Fitting
14	*59300	1	Reservoir Gasket
15	66083GY8	1	Reservoir (2 gallon)
16	253564	1	Oil Line Tube
17	253473	1	Tube Fitting
18	253563	1	Oil Line Tube
19	17586	1	Sight Gauge
20	17147	1	Plug Fitting (7/16)
21	10396	1	Hex Jam Nut (3/4-16)
22	351000	1	Drain
23	14725	1	O-ring (1.12 x .93 Nitrile)
24	251486	8	Button Hd. Screw (10-24 x 1/2)
25	*350925	1	Filler Cap
26	59298GY8	1	Handle

Part numbers marked with an asterisk (*) are contained in Maintenance Kit No. 090203.

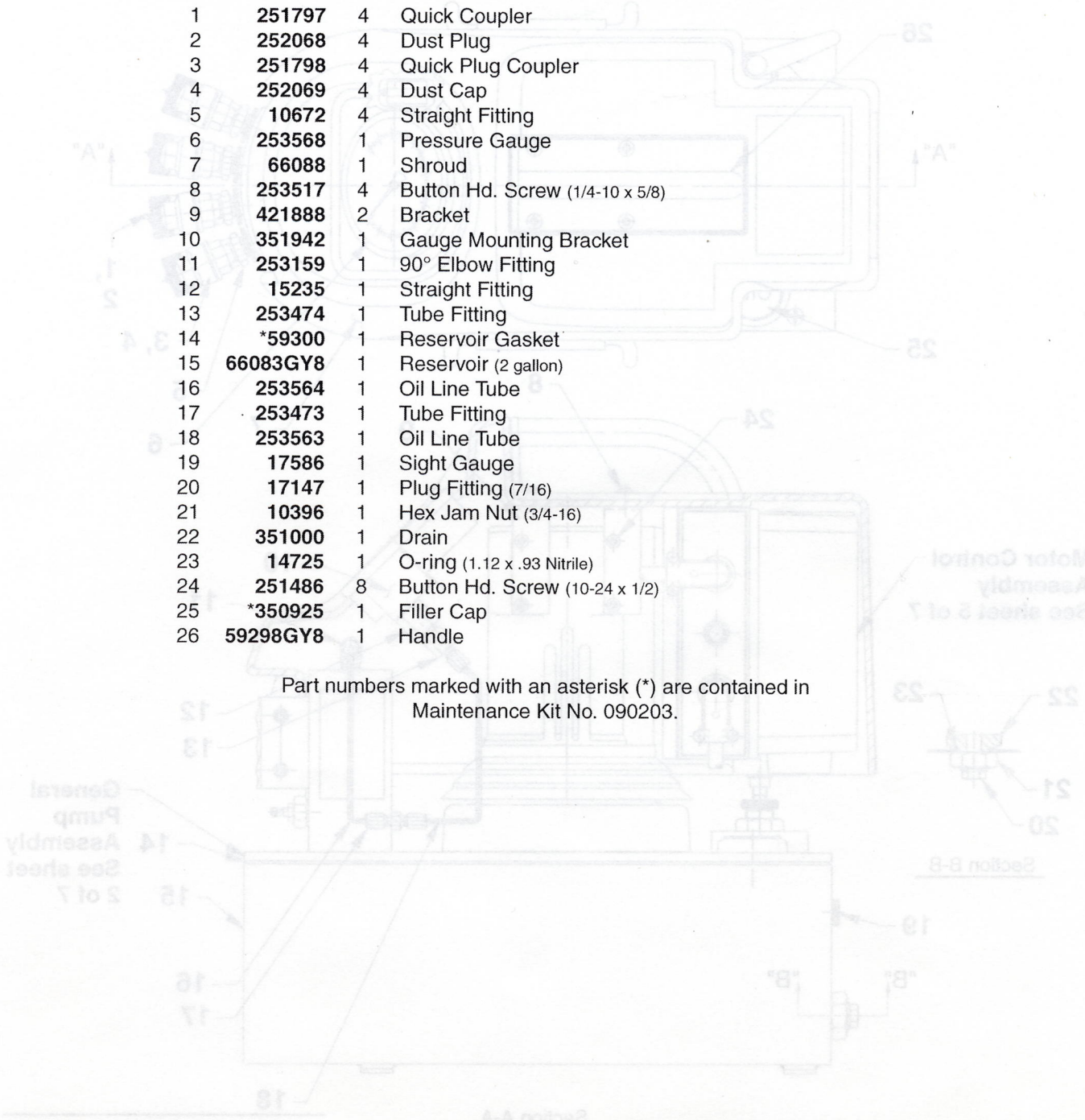

GENERAL PUMP SIDE VIEW

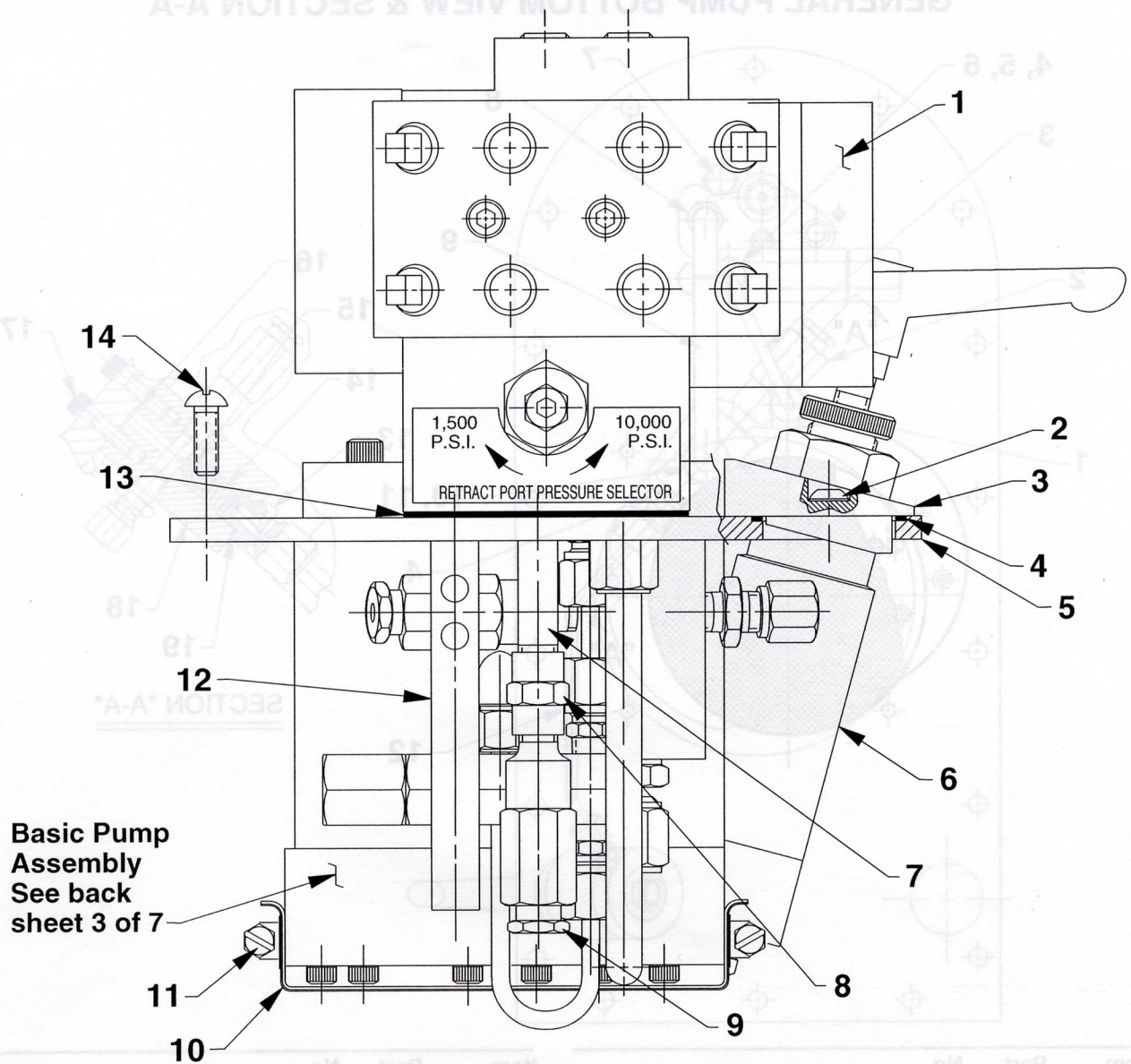

Item No.	Part No.	No. Req'd	Description
1	421860	1	Valve Assembly (See Form No. 105549)
2	253517	2	Button Hd. Screw (1/4-20 x 5/8)
3	421886	1	Regulator Plate
4	14875	1	O-ring (1.62 x 1.50 Nitrile)
5	66084GY8	1	Cover Plate
6	421429	1	Pressure Regulator Assembly (See sheet 3 of 7)
7	15456	2	Straight Fitting

Item No.	Part No.	No. Req'd	Description
8	18841	1	Straight Fitting
9	*21278-15	1	Relief Valve Assembly (Set at 1,500/1,700 PSI)
10	†350304	1	Filter
11	†350995	1	Hose Clamp
12	250630	1	Drain Tube
13	351095	1	Valve Gasket
14	10177	18	Rnd. Hd. Screw (1/4-20 x 3/4)

Part numbers marked with an asterisk (*) are contained in Maintenance Kit No. 090203.

Part numbers marked with a dagger (†) are contained in Replacement Basic Pump Assembly No. 501052.

Sheet No. 2 of 7

Rev. Date: 27 Sept. 2000

GENERAL PUMP BOTTOM VIEW & SECTION A-A

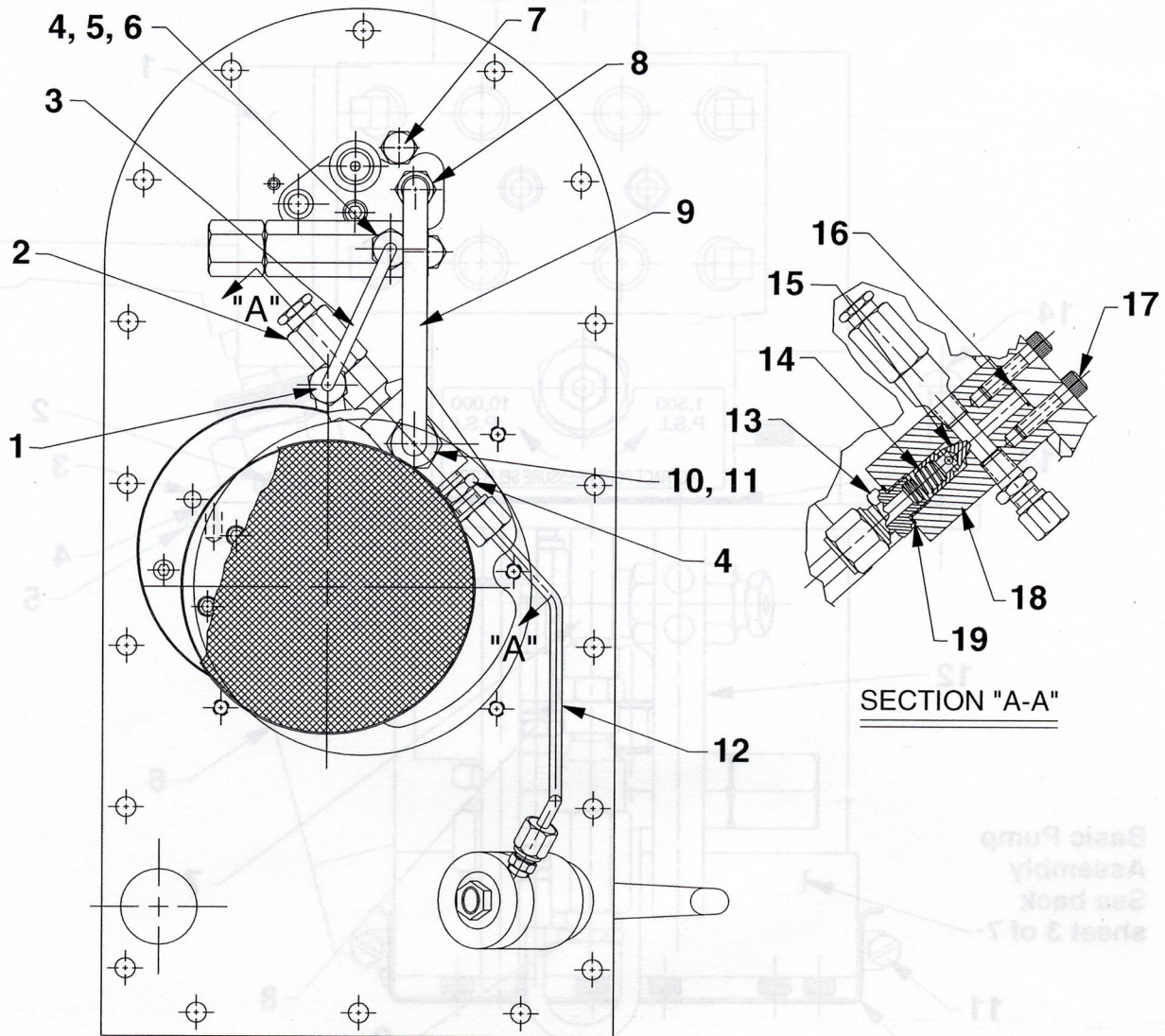

Item No.	Part No.	No. Req'd	Description
1	16177	2	90° Elbow Fitting
2	†*21278	1	Relief Valve Assembly (Set at 10,100/10,700 PSI)
3	253562	1	Pressure Regulator Tube
4	14844	5	Straight Fitting
5	21943	1	Accumulator
6	360029	1	Oil Line Tube
7	12825	3	Cap Screw (1/4-20 x 5/8)
8	10661	1	Straight Fitting
9	253476	1	Oil Line Tube
10	10430	1	Tube Sleeve

Item No.	Part No.	No. Req'd	Description
11	10431	1	Tube Nut Fitting
12	253561	1	Pressure Regulator Tube
13	†20770	1	Connector Fitting
14	†10425	1	Spring (.37 OD x .75 x .03 WS)
15	†20771	1	Poppet
16	†10266	1	O-ring (.37 x .25 Nitrile)
17	†10015	2	Soc. Hd. Screw (1/4-28 x 1; Torque to 160/170 in. lbs.)
18	†20776	1	Valve Body
19	†10261	1	Copper Washer (.75 x .60)

Part numbers marked with an asterisk (*) are contained in Maintenance Kit No. 090203.

Part numbers marked with a dagger (†) are contained in Replacement Basic Pump Assembly No. 501052.

#421429 PRESSURE REGULATOR ASSEMBLY

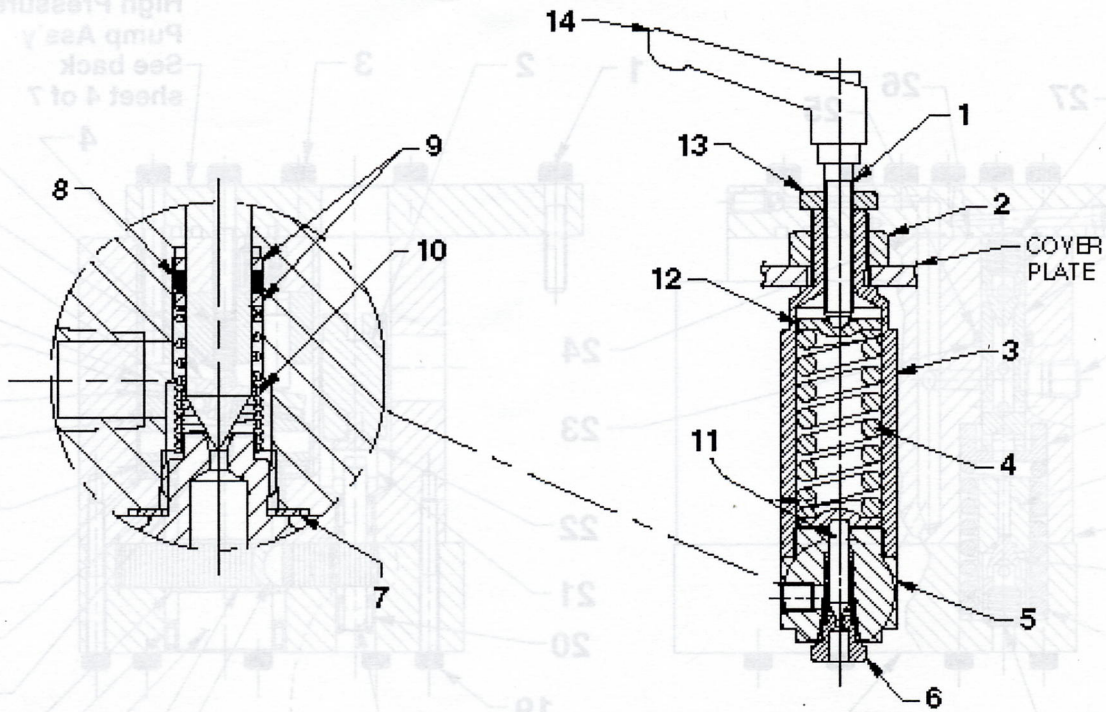

Item No.	Part No.	No. Req'd	Description
1	252427	1	Adjustment Stem (Note: Assemble to handle with Loctite 242 or equiv.)
2	10396	1	Jam Nut
3	351350	1	Regulator Housing
4	215429	1	Compression Spring (1.100 O.D. X 2-1/2 Lg.)
5	420891	1	Regulator Body
6	*351343	1	Seat Fitting (Torque to 440/460 in. lbs.)
7	*14874	1	Copper Washer (.700 X 1/2 X 1/32)

Item No.	Part No.	No. Req'd	Description
8	*10266	1	O-ring (3/8 X 1/4 X 1/16)
9	*215430	2	Backup Washer (.385 x .282 x .050)
10	215431	1	Spring (3/8 O.D. x 21/32 Lg.; Note: Assemble closed coils of spring form towards seat fitting [Item#6])
11	*309079	1	Poppet
12	215428	2	Spring Retainer (Grease pocket before assembling [both ends])
13	215683	1	Regulator Locking Nut
14	252332	1	Adjustable Handle

Part numbers marked with an asterisk (*) are contained in Maintenance Kit No. 090203.

BASIC PUMP ASSEMBLY

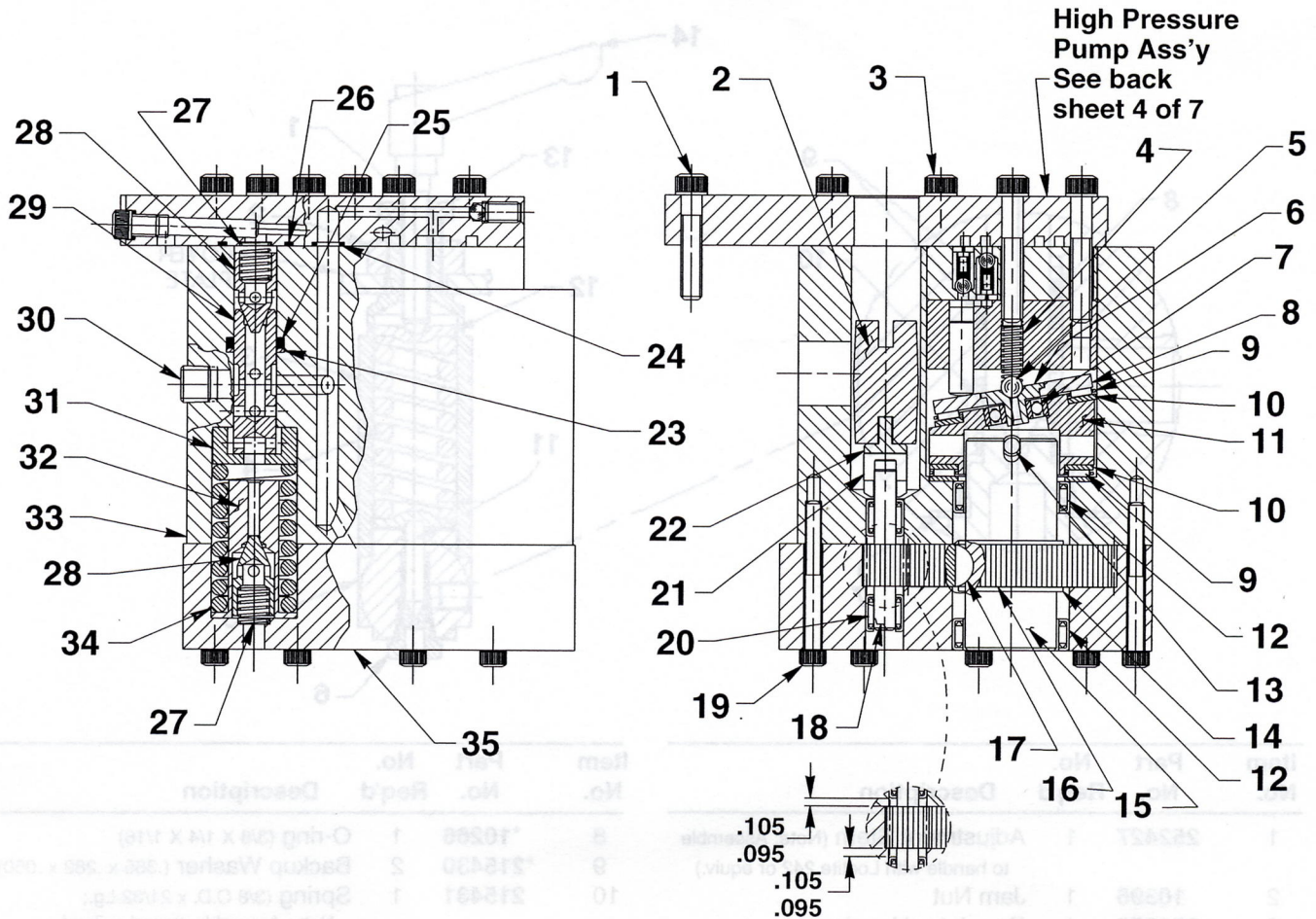

Item No.	Part No.	No. Req'd	Description
1	10016	3	Soc. Hd. Screw (1/4-20 x 1)
2	†*21091	1	Coupling
3	†10020	9	Soc. Hd. Screw (1/4-20 x 1-1/4; Torque to 170/180 in. lbs.)
4	†10361	1	Spring (.25 OD x 1" x .03 WS)
5	†10375	1	Ball (1/4 dia. steel)
6	†23547	1	Bearing Top Plate
7	†11814	1	Ball Bearing
8	†23548	1	Top Plate
9	†11228	2	Needle Bearing
10	†11813	3	Bearing Race
11	†23549	1	Angle Plate
12	†11064	2	Needle Bearing
13	†11955	1	Spring Slotted Pin (.25 x 1.75)
14	†11261	2	Ext. Retaining Ring (1.05 x .050)
15	†23556	1	Shaft
16	†23574	1	Drive Gear
17	†11821	1	Woodruff Key
18	†20774	1	Connector Fitting (9/16 x 5/8)

Item No.	Part No.	No. Req'd	Description
19	†10001	13	Soc. Hd. Screw (10-32 x 1-3/4; Torque to 50/60 in. lbs.)
20	†11198	2	Needle Bearing
21	†21093	1	Key
22	†21092	1	Adapter
23	†12389	1	Backup Washer (.69 x .50)
24	†10266	1	O-ring (.37 x .25 Nitrile)
25	†10271	1	O-ring (.68 x .50 Nitrile)
26	†10303	1	O-ring (.87 x .75 Nitrile)
27	†10425	2	Spring (.37 OD x .75 x .03 WS)
28	†20771	2	Poppet
29	†20849	1	Spool
30	†10427	1	Plug Fitting (1/8 NPTF)
31	†23255	1	Spring Guide
32	†23256	1	Spring Guide
33	†40071	1	Pump Body
34	†10426	1	Spring (1" OD x 1.8 x .19 WS)
35	†65334	1	End Plate

Part numbers marked with an asterisk (*) are contained in Maintenance Kit No. 090203.

Part numbers marked with a dagger (†) are contained in Replacement Basic Pump Assembly No. 501052.

HIGH PRESSURE PUMP ASSEMBLY

See Diagram
on Reverse
Side for
Important
Ass'y.
Information

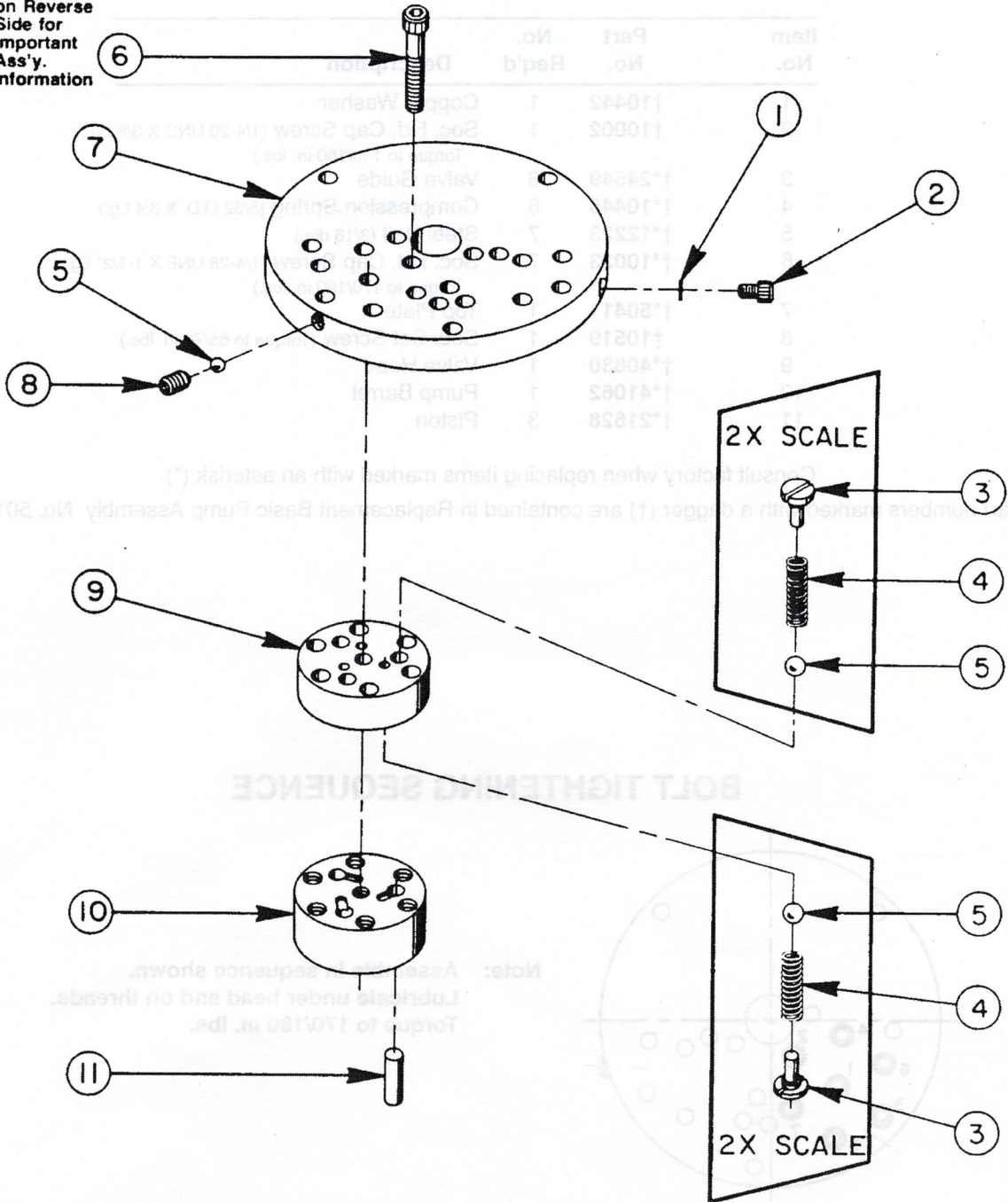

HIGH PRESSURE PUMP ASSEMBLY

33113 HIGH PRESSURE PUMP ASSEMBLY

3 Pistons --- 9/32 Dia.

Item No.	Part No.	No. Req'd	Description
1	†10442	1	Copper Washer
2	†10002	1	Soc. Hd. Cap Screw (1/4-20 UNC X 3/8 Lg.; Torque to 140/160 in. lbs.)
3	†*24549	6	Valve Guide
4	†*10445	6	Compression Spring (5/32 O.D. X 3/4 Lg.)
5	†*12223	7	Steel Ball (3/16 dia.)
6	†*10023	7	Soc. Hd. Cap Screw (1/4-28 UNF X 1-1/2" Lg.; Torque to 170/180 in. lbs.)
7	†*50411	1	Top Plate
8	†10519	1	Soc. Set Screw (Torque to 65/70 in. lbs.)
9	†*40630	1	Valve Head
10	†*41062	1	Pump Barrel
11	†*21628	3	Piston

Consult factory when replacing items marked with an asterisk (*).

Part numbers marked with a dagger (†) are contained in Replacement Basic Pump Assembly No. 501052.

BOLT TIGHTENING SEQUENCE

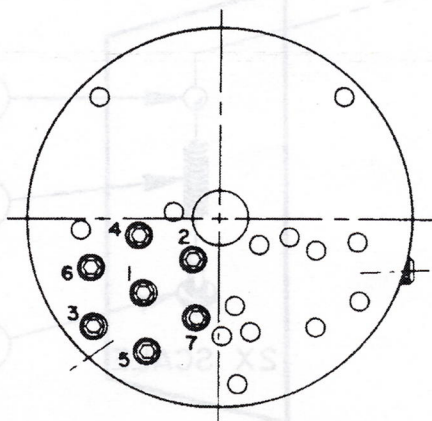

Note: Assemble in sequence shown.
Lubricate under head and on threads.
Torque to 170/180 in. lbs.

MOTOR AND CONTROL ASSEMBLY

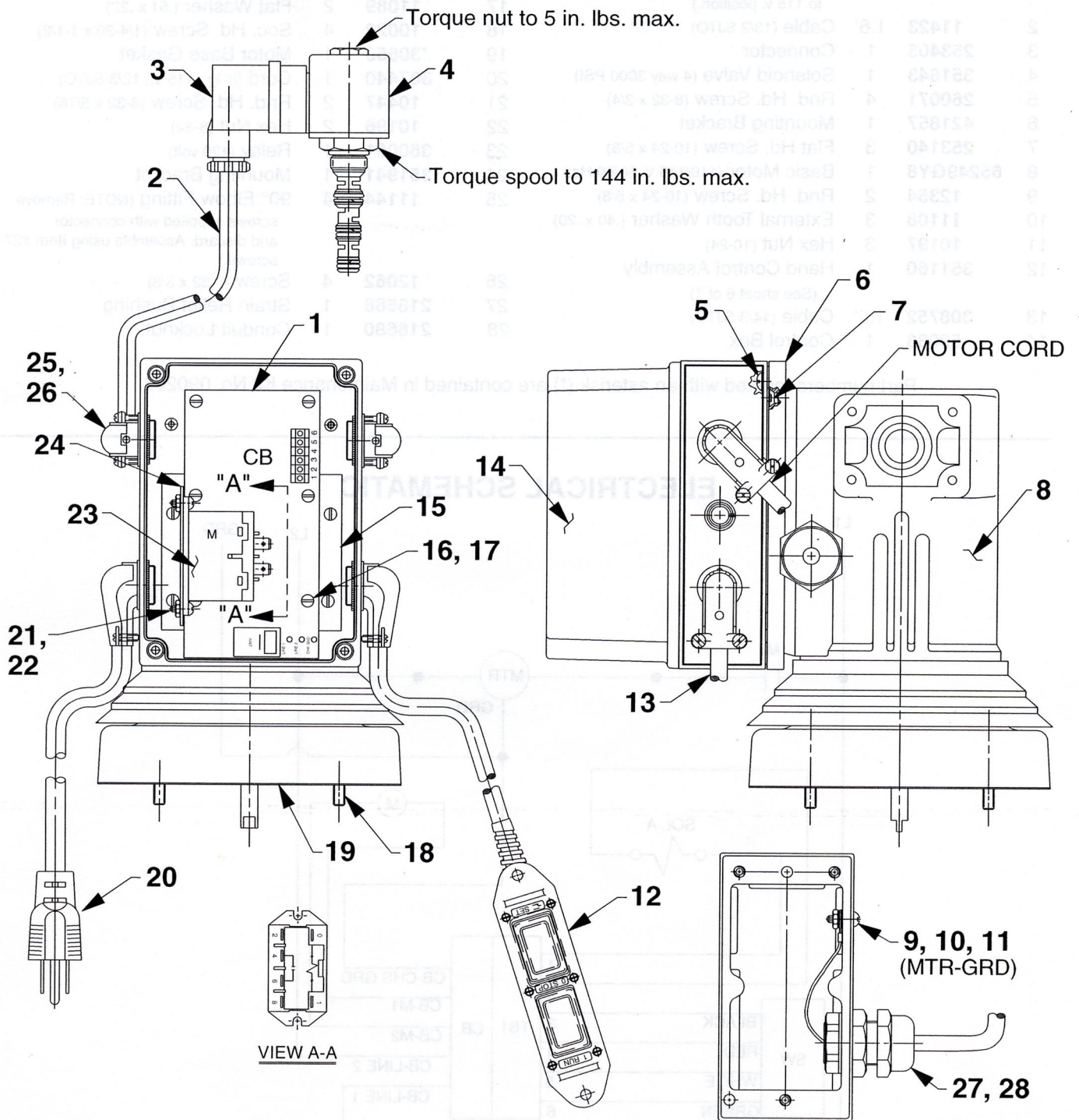

Parts List, Form No. 108152, Back sheet 5 of 7

Item No.	Part No.	No. Req'd	Description
1	421477	1	Circuit Board (NOTE: Set input voltage selector switch to 115 v. position.)
2	11423	1.6'	Cable (18/2 SJTO)
3	253405	1	Connector
4	351843	1	Solenoid Valve (4 way 3000 PSI)
5	260071	4	Rnd. Hd. Screw (8-32 x 3/4)
6	421857	1	Mounting Bracket
7	253140	3	Flat Hd. Screw (10-24 x 5/8)
8	65249GY8	1	Basic Motor (110/115 V. 50/60 Hz.)
9	12354	2	Rnd. Hd. Screw (10-24 x 5/8)
10	11108	3	External Tooth Washer (.40 x .20)
11	10197	3	Hex Nut (10-24)
12	351160	1	Hand Control Assembly (See sheet 6 of 7)
13	308752	1.6'	Cable (14/3 SJTO)
14	59036	1	Control Box

Item No.	Part No.	No. Req'd	Description
15	351588	1	Mounting Plate
16	12409	4	Rnd. Hd. Screw (8-32 x 5/8)
17	11089	2	Flat Washer (.51 x .22)
18	10022	4	Soc. Hd. Screw (1/4-20 x 1-1/2)
19	*30650	1	Motor Base Gasket
20	307440	1	Cord (8' lg.; 115 V.; 12/3 SJTO)
21	10447	2	Rnd. Hd. Screw (8-32 x 5/16)
22	10196	2	Hex Nut (8-32)
23	360001	1	Relay (120 volt)
24	351941	1	Mounting Bracket
25	11144	4	90° Elbow Fitting (NOTE: Remove screws supplied with connector and discard. Assemble using Item #27 screws.)
26	12062	4	Screw (8-32 x 3/8)
27	216666	1	Strain Relief Bushing
28	216680	1	Conduit Locknut

Part numbers marked with an asterisk (*) are contained in Maintenance Kit No. 090203.

ELECTRICAL SCHEMATIC

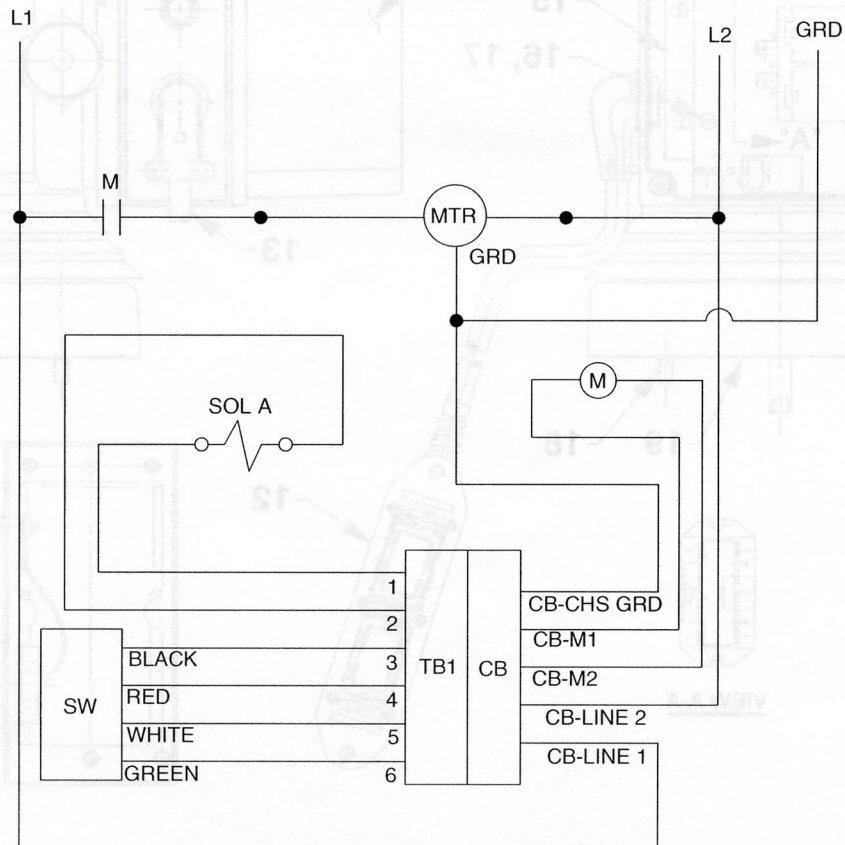

#351160 REMOTE HAND SWITCH ASSEMBLY

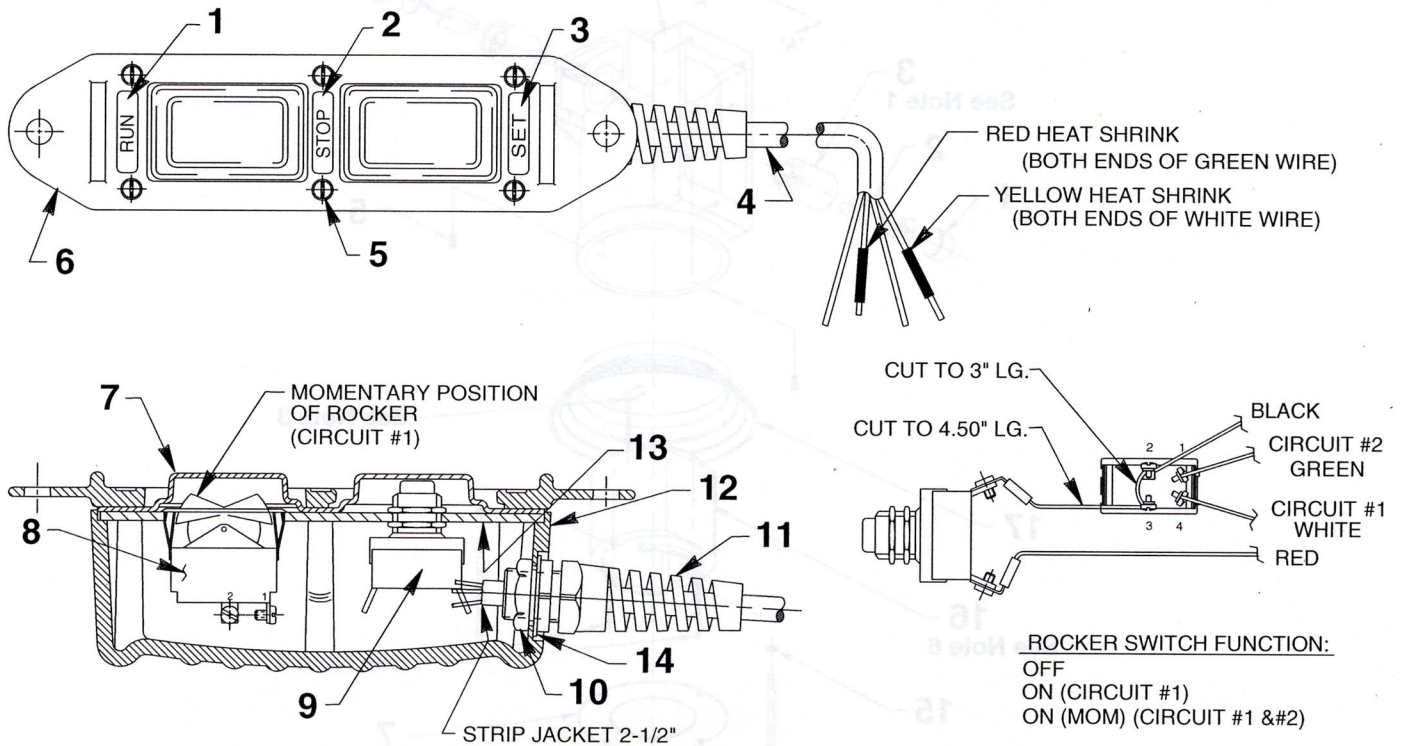

Item No.	Part No.	No. Req'd	Description
1	203770	1	Decal (Run)
2	203769	1	Decal (Stop)
3	252431	1	Decal (Set)
4	11391	21'	Cable (18/4 SJTO)
5	250248	6	Screw (4-24 X 3/4 Lg.)
6	251044	1	Plastic Cover
7	*420050-2	1	Gasket

Item No.	Part No.	No. Req'd	Description
8	420017	1	Rocker Switch
9	253197	1	Push Button Switch
10	251802	1	Locknut
11	251818	1	Strain Relief Bushing
12	420050-4	1	Switch Housing
13	420050-5	1	Switch Mounting Plate
14	253607	1	Gasket

Part numbers marked with an asterisk (*) are contained in Maintenance Kit No. 090203.

ELECTRIC MOTOR ASSEMBLY

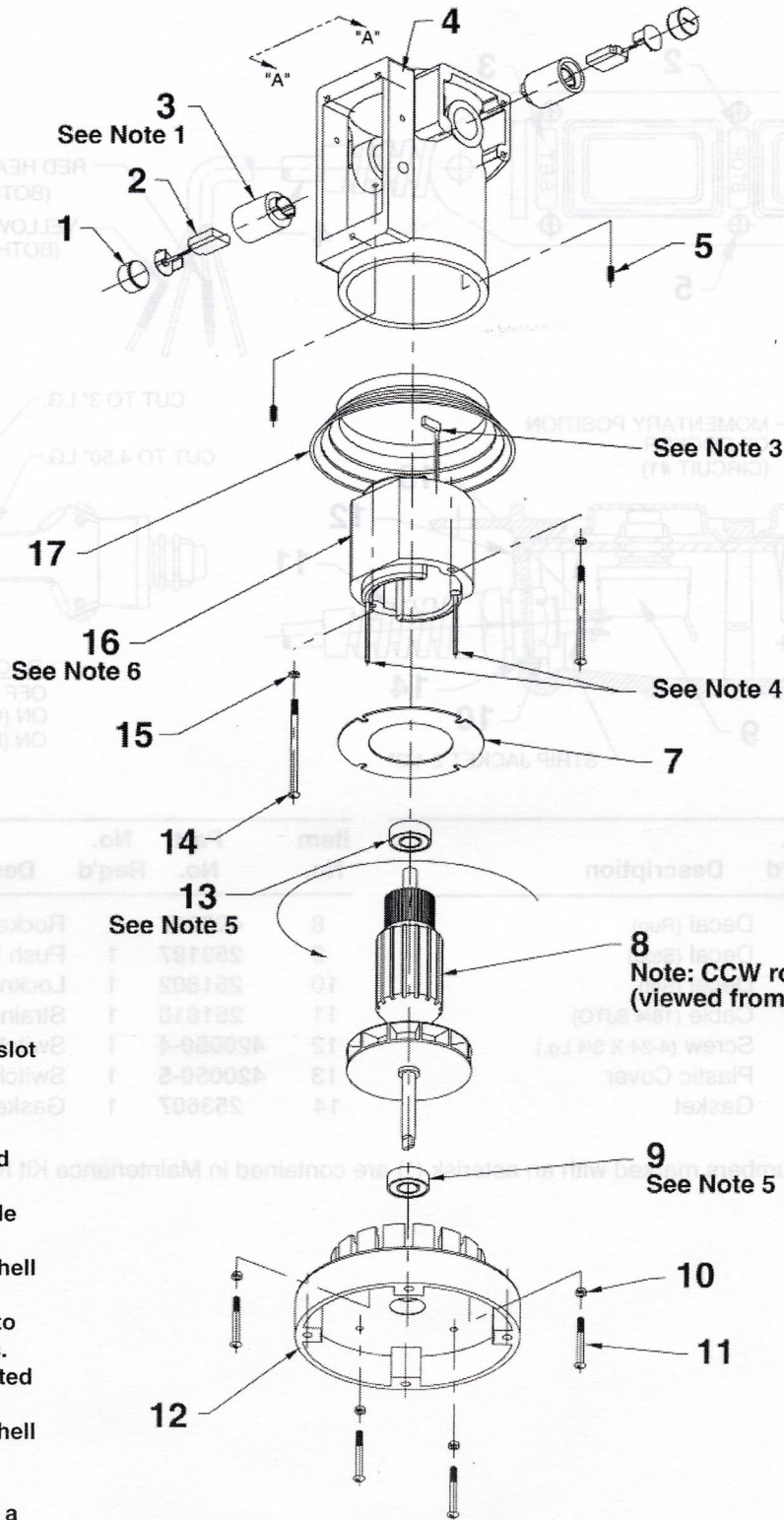

Notes:

1. Bush holders (#10805) must be installed with slot and dimple facing the open end of the motor shell casting.
2. Stator must be installed with part no. and date code up (must be visible thru the rectangular opening in the motor shell casting).
3. Insert flag terminals into adjacent brush holders.
4. Line leads must be routed thru the rectangular opening in the motor shell casting.
5. Press bearings into armature and install as a unit into the motor shell casting.

8
Note: CCW rotation
(viewed from shaft end)

9
See Note 5

Item No.	Part No.	No. Req'd	Description
1	10806	2	Brush Holder Cap
2	*10804	2	Brush
3	10805	2	Brush Holder
4	65064	1	Motor Shell
5	10133	2	Set Screw (#10-24 UNC X 1/4 Lg.)
7	20786	1	Baffle Plate
8	10800	1	Armature (115 volt)
9	10438	1	Ball Bearing
10	10241	4	Lockwasher (For #10 bolt)
11	10169	2	Screw (#10-24 UNC X 2" Lg.; Torque to 20/25 in. lbs.)
12	40059WH2	1	Motor Base
13	10439	1	Ball Bearing
14	10170	2	Screw (#10-24 UNC X 3-1/4 Lg.)
15	12356	2	Washer (#10 Internal Tooth)
16	10802	1	Field (115 volt)
17	421204	1	Plastic Cover

Part numbers marked with an asterisk (*) are contained in Maintenance Kit No. 090203.

BRUSH HOLDER & ARMATURE INSTALLATION SPECIFICATION

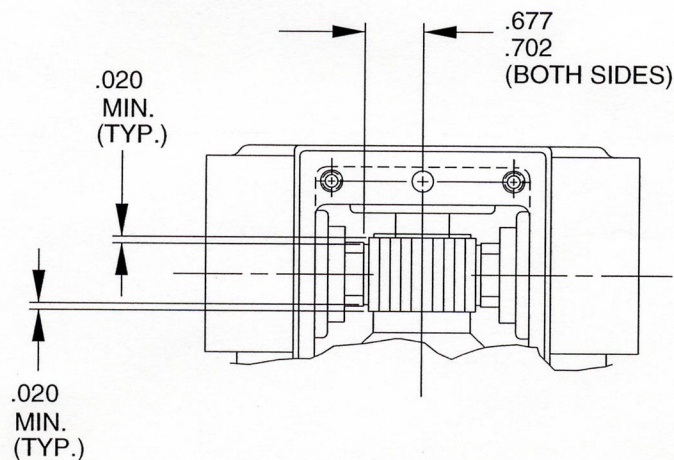

When replacing brushes or the armature, the dimensions shown must be as specified.